

Full Length Research Paper

Investigation of using ansys software in the determination of stress behaviours of masonry walls under out of plane cycling load

Recep Kani¹ and M. Sami Döndüren^{2*}

¹Gazi University, Technical Education Faculty, Construction Department, 06500, Ankara, Turkey.

²Selcuk University, Faculty of Engineering and Architecture Civil Engineering Department, 42079, Selcuklu, Konya, Turkey.

Accepted 14 December 09

In this study, a model masonry wall (MW) was constructed in the laboratory and experimented under out of plane cycling load. Then it was analyzed with ANSYS which is a finite element technology. After analyzing this selected model masonry wall with ANSYS programme, the results of strength, displacement and stress distributions obtained were compared with the values of the experiments. Thus, the usability of ANSYS programme in the analysis of masonry walls was searched. As a result of the experiments, it was observed that the first cracking load was 45 kN, fracture load was 65 kN and the maximum value of the displacement for MW under out of plane cycling load was 4.0 mm in both of the applications. When the stress distributions were taken into consideration in the experiments and solutions of ANSYS, it was observed that the stresses occurred on the uppermost horizontal plane in the middle of the wall and decreased through basic connection beam. Consequently, it can be said that ANSYS programme can be used in the analysis of masonry walls under out of plane cycling load and ductility, rigidity and energy consumption capacities of masonry walls can be calculated with the data obtained.

Key words: Masonry, ANSYS programme, wall, stress behaviour, horizontal load, earthquake.

INTRODUCTION

Generally all over the world, masonry constructions are the commercially available ones in rural areas. The earthquakes occurring in the various regions of the world show that most of the masonry constructions in rural areas should be reinforced against earthquakes. However, the researches performed for the behaviours of constructions against the effect of earthquakes are focused on reinforced and steel constructions. As a natural result of this, the project engineer has inadequate information about the behaviour of masonry constructions against earthquake (Döndüren, 2008).

Since the masonry constructions, as a necessity of construction technology, are constructed by connecting stone and/or bricks with the mortar, they do not usually form a medium. For this reason, it is quite difficult to introduce the behaviours of masonry walls with numerical

methods (Hamous et al., 2002). Before starting the improvement and reinforcement studies for masonry constructions, the behaviour and the failure mechanism of the masonry construction under the effect of earthquake should be known well (Hendry, 1990). In masonry constructions, the walls carry the horizontal and vertical loads. The horizontal loads such as wind, earthquake, etc. cause in plane and out of plane enforcements in the walls. Shear forces and moments are formed in masonry constructions under horizontal loads. As a result of this, in plane failure of masonry wall occurs with the effect of axial forces such as pressure/tensile that the moment forms and/or inclined noble stresses that are formed by failure forces (Begimgil, 1991).

Various methods have been developed and applied for the analysis of masonry constructions up till today. These methods are given as follows and described shortly:

- Geometric load factor.
- Linear elastic finite element analysis.

*Corresponding author. E-mail: sdonduren@selcuk.edu.tr

- Limit block analysis.
- Non-linear elastic-plastic finite element method.
- Differential element method.

Geometric load factor method is described as the rate of masonry element thickness of security factor to the minimum thickness that can correspond this applied load. Deformations that occur in the elements under load cannot be calculated by this method. The results of the analysis are mostly depend on the decision of the engineer. The deformations formed in masonry element under working loads (admissible loads) can be calculated by linear elastic finite element method, however, the failure mechanism and failure load cannot be determined. In limit block analysis, fracture load and mechanism can be calculated by assuming that the masonry construction is formed of rigid blocks. Deformations, failure mechanism and plastic regions of masonry construction can be calculated by non-linear elastic-plastic finite element method. However, the most important disadvantage of this method is to solve this masonry construction including discontinuities by assuming it as a continuous medium. For this reason, it's necessary to represent anisotropic masonry construction system including discontinuities with equivalent deformation module and strength parameters (Kanit et al., 2006).

In this study; the constructed model wall (MW) was analyzed with a finite element programme, that is, ANSYS, and then a wall with similar properties was constructed in the laboratory and experimented under cycling loads. ANSYS programme and the experimental results were compared in terms of strength, displacement and stress distributions and the usability of ANSYS programme in the analysis of masonry walls were investigated.

MATERIALS AND METHODS

Experimental element

The geometrical properties of the wall which was experimented under reverse-cycling load are given in Figure 1. As it can be seen, the experimental element is an MW and has a dimension of 2.7 x 2.1 m. The brickwork of MW is shown in Figure 2. The amounts of materials in the mixture of mortar that was used in the network of bricks are given in Table 1. Finally, the form of constructed MW is given in Figure 3.

Properties of ANSYS programme

Finite element is a mathematical method which makes calculations by dividing complex structures into very little elements. ANSYS programme is a programme which puts forth the performance and possible fracture loads of constructions into consideration in virtual medium. The programme puts forward how a whole construction collecting the behaviour and effect of every little piece in the system will display a behaviour. The results can be obtained as tables or graphics (Gabor et al., 2005).

The solution of very complex systems as geometrical scale or an equation can be made with ANSYS programme. Therefore, it can

be used in the modelling of brick masonry constructions effectively. However, only the researches about this subject can frequently be found in the literature (Gabor et al. 2005). In order to get the solution with ANSYS programme, the following procedures should be carried out:

- First step is to put forth the physical model into consideration. The geometric model of the wall that will be modelled in three dimensional space is formed by using graphical procedure interface of ANSYS programme.
- Second step includes the introduction of material properties. For this reason, the reinforced concrete material element, fracturality, high pressure strength and tensile strength close to zero which are present in the library of the programme are all suitable for the modelling of the brick wall. Moreover, brick element formulation which is a suitable element type for rigid modelling is also present in the library.
- Third step is the process for dividing (mesh) three-dimensional model into elements.
- Final step, on the other hand, is the introduction of limit conditions, that is, support conditions.

After the completion of modelling process, the matrix solution processor of ANSYS programme is used in order to determine the rigidity matrix that will be obtained with the programme as well as displacement matrix as a product. In this study, iterative solution system which is a numerical method depending on trial and error was used for brick behaviour having non-linear behaviour. The solution was performed by using stages depending on displacement increment instead of load increments (Gabor et al., 2005).

APPLICATION

ANSYS application

In modeling the masonry specimens, eight-noded isoparametric element to simulate the masonry units and three-noded isoparametric interface element of zero thickness located between material elements to model the interface characteristics of the joint and bond between block and mortar. For Finite Element Modeling (FEM) of the masonry prisms, SOLID45 elements in ANSYS element library are used for the 3-D modeling of solid structures. The element is defined by eight nodes having three degrees of freedom at each node: translations in the nodal x, y, and z directions. The element has plasticity, creep, swelling, stress stiffening, large deflection, and large strain capabilities (Gabor et al., 2005).

The masonry units and mortar layers are modeled independently and different material properties are attained. The elaborate FE model developed in this study, masonry units are linked to the mortar units by series of nonlinear springs, which is also available in the ANSYS library. COMBIN39 is a unidirectional element with nonlinear generalized force-deflection capability that can be used in any analysis. The longitudinal option is a uniaxial tension-compression element with up to three degrees of freedom at each node: translations in the nodal x, y, and z directions. No bending or torsion is considered. The element has large displacement capability for which there can be two or three degrees of freedom at each node. The element is defined by two (preferably coincident) node points and a generalized force-deflection curve. The springs are introduced to handle the tensile and shear stress failure in the mortar joints Figure 4 (Abruzzese, 2009).

The main problem in the development of accurate stress analysis for masonry structures is the definition and the use of suitable material constitutive laws. The complex interaction between block units, dry joint and grouting material has to be well understood under different stages of loading; that is, elastic, inelastic and failure. The stress-strain behaviour of masonry blocks and grout

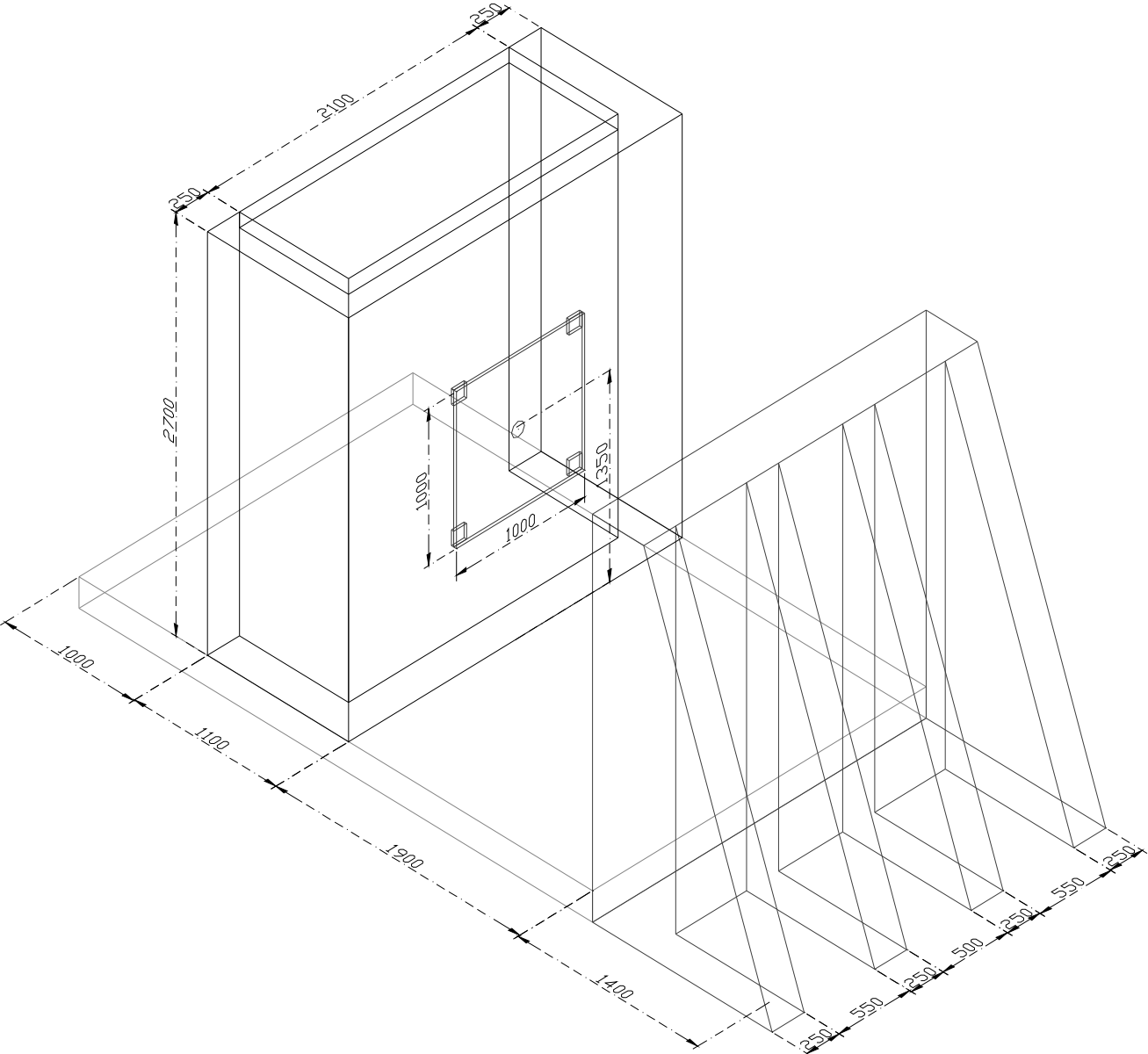

Figure 1. Geometrical properties of model wall and reaction wall

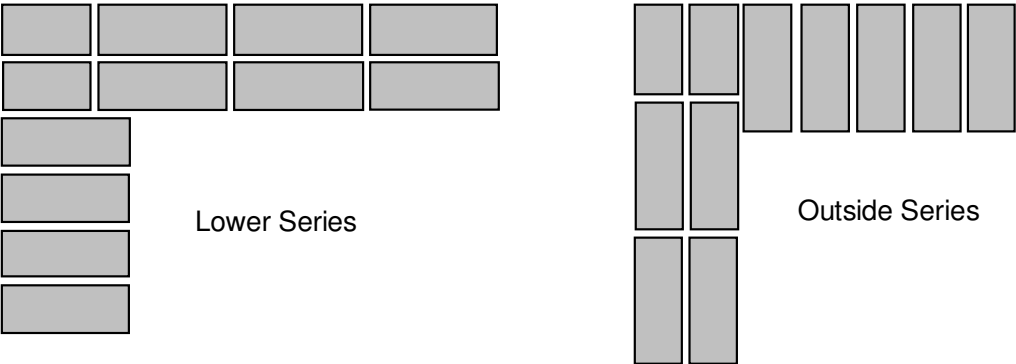

Figure 2. The brickwork of experimental masonry wall

Table 1. The amounts of materials in the mixture of mortar that was used in the network of bricks (1 m³).

Fine sand	Cement	Water
1 m ³	0.200 t	0.200 m ³



Figure 3. Model wall.

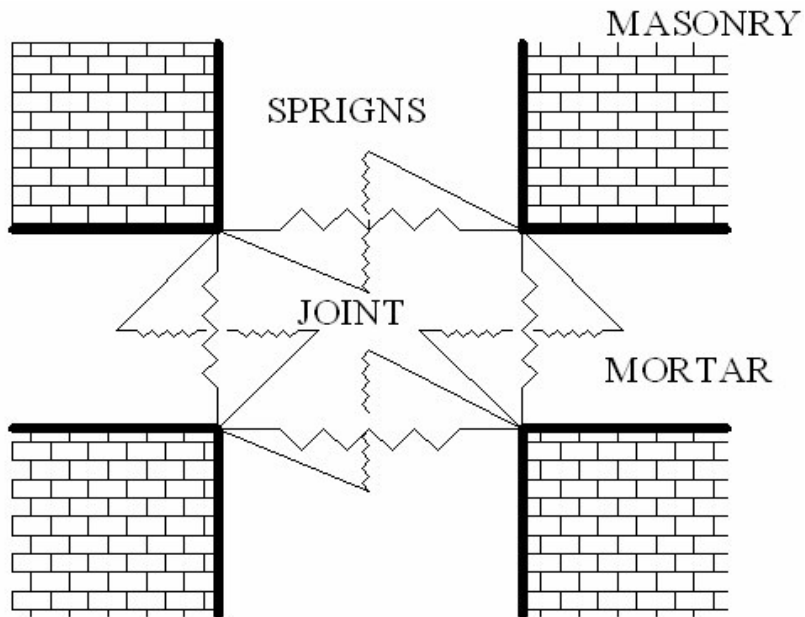

Figure 4. Mortar-brick joint interface modelling.

materials under compression for stress state was modelled. Material nonlinearity in the compressive stress field is considered for the masonry constituents (block and grout) in the orthogonal directions and the effect of cracking and softening on the masonry are included. The model allows for the progressive local failure of the masonry materials after cracking, the compressive strength re-

duction in the cracked block is considered (Fathy, 2008). The material model for the masonry panel was assumed to be orthotropic parallel and normal to the bed joints. The material stress versus strain relationship is represented in Figure 5.

The incremental full Newton-raphson iterative solution procedure was used in order to account for both large deformation effects and

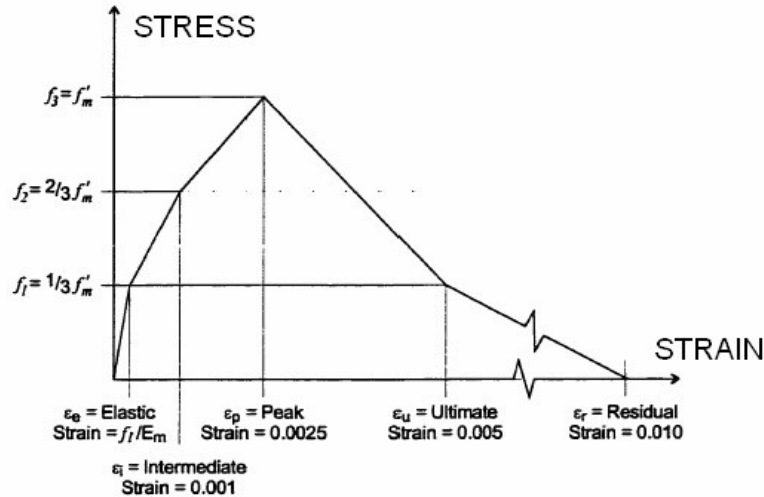

Figure 5. Stress versus strain relationship.

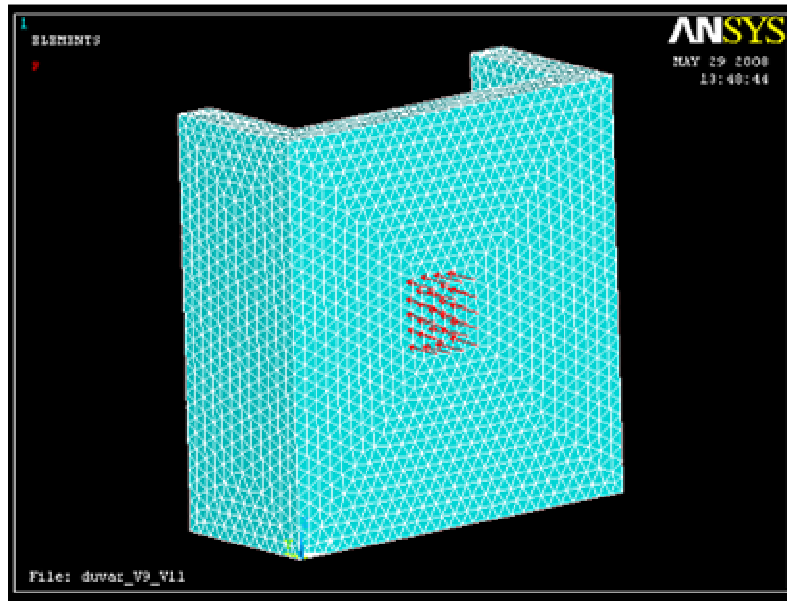

Figure 6. Loading scheme and mathematical modeling.

material plasticity. In order to capture the complete load-deflection behavior including the post peak response, the top node of the masonry prism was subjected to a vertical downward displacement. The magnitude of this displacement was sufficiently greater than that observed in the actual test after which a load-deflection plateau was attained indicating that the contribution of the infill almost entirely diminished and that no appreciable increase in load resistance occurred (Mallardo, 2007). In the present model, the significant parameters that govern the bond between the block and grouts are the tensile bond strength and shear bond strength of the interface. Separation occurs when the normal force across the interface is tensile and its value exceeds the tensile bond strength and nodes located at both sides of the interfaces are free disconnected and become separately. Shear failure is initiated along the block-mortar interface when the shear stress is more than or equal to the shear strength. In this case, the interface is assumed to lose the shear stiffness when the shear stress is more than the shear strength.

interface is assumed to lose all its stiffness when normal stress reaches the compressive strength of the weaker material brick or mortar. Moreover, when the normal stress is tension and more than tensile bond strength the interface will lose all its stiffness at that point (Mallardo, 2007).

The masonry specimen is modeled in 1/1 scale and the loading is applied to the middle of the front panel. The base of the specimen is constrained in all directions and also rations are fixed. In the first model only masonry and mortar exist. The loading of the model is given in Figure 6.

Experiment

In order to understand the behaviour and fracture style of out of plane loaded MW, the positions of MW concerning cycling load application and reaction wall are shown in Figure 7.

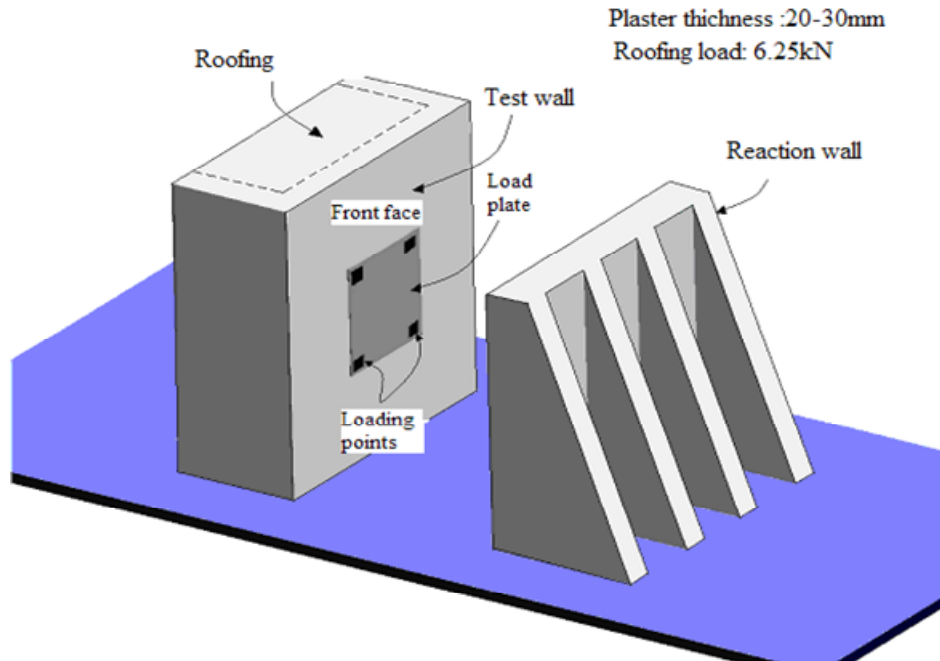

Figure 7. The positions of model and reaction walls.

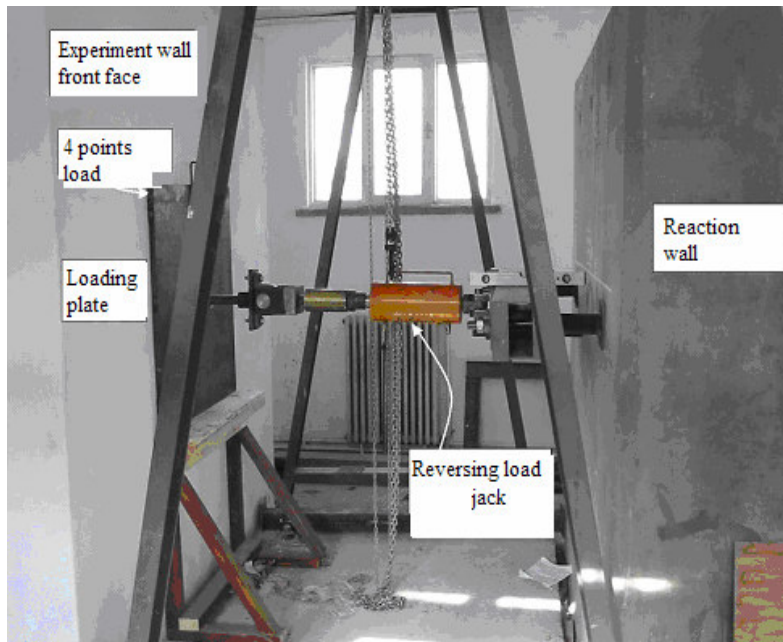

Figure 8. Loading mechanism

The loading mechanism is given in Figure 8. The load is given with a jack that applies pressure and tensile in bidirectional movement. A rigid steel rod passes through the hole in the middle of the wall. An identical loading plate is also present at the back of the wall. The pressure/tensile movement applied to the wall and the cycling effect of seismic forces were modelled. It was accepted that the loading plate together with the loads applied in the middle of the wall would form an enforcement similar to the moment distribution

of uniform distributed load.

FINDINGS

ANSYS solution and findings

1/1 scaled MW was modelled in the real geometric dimensions. Its

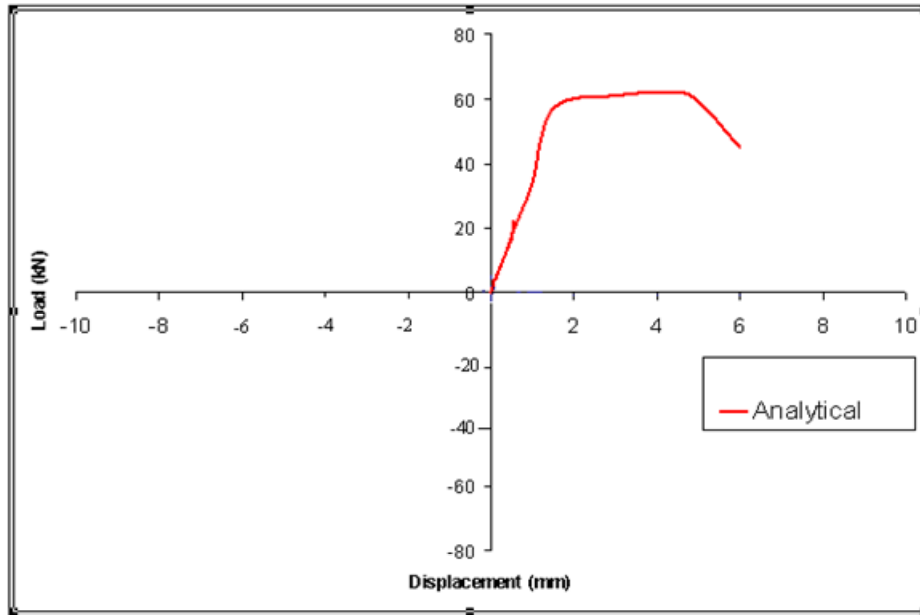

Figure 9. Analytical load-displacement graph of experimental sample

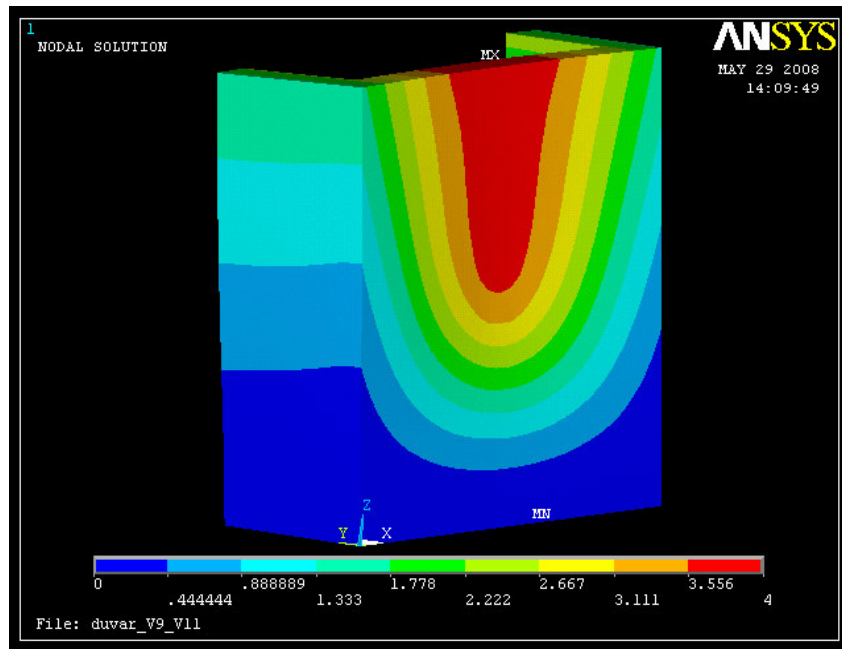

Figure 10. Y displacement distribution of the sample under horizontal loads.

movement was prevented by supporting the floor of MW and the loading was given in the middle of the loaded wall. The load-displacement graph that was obtained as a result of ANSYS application is given in Figure 9. When load-displacement graph is examined; The first crack in MW was under $f_c=45 \text{ kN}$ load and 2.0 mm displacement occurred at the time of crack, The first crack under out of plane cycling load occurred within the elastic limits, The power consumption of MW occurred in a magnitude of $f_u = 65 \text{ kN}$ load made a displacement with 4 mm at this point,

It was observed that there was a rapid decrease in the load-carrying capacity of MW after it reached its power consumption point. Y displacement distribution of MW under out of plane cycling load is given in Figure 10.

When Figure 10 is examined, it can be observed that the maximum displacement occurred as 4.0 mm in the middle of MW, the displacement values decreased downwards in vertical plane and the uppermost point made more displacement than other horizontal points.

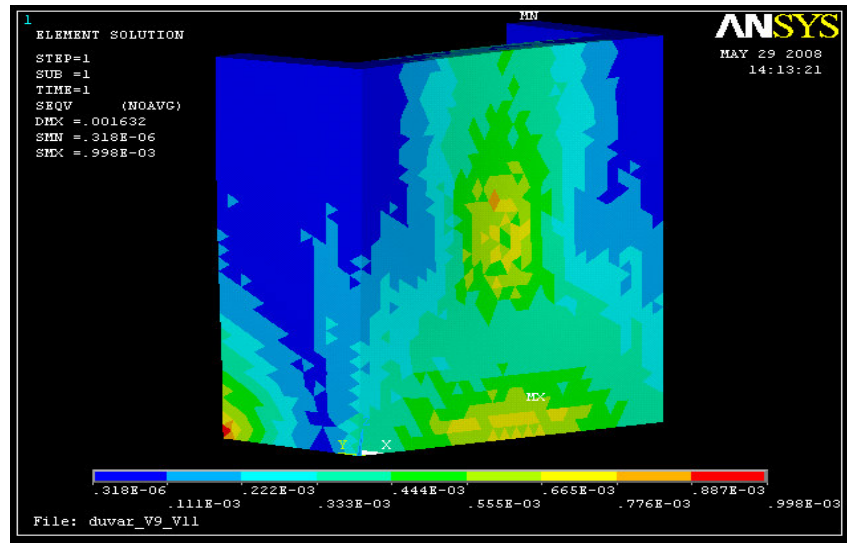

Figure 11. Von-Misses stress distribution occurred in the sample under horizontal load effect.

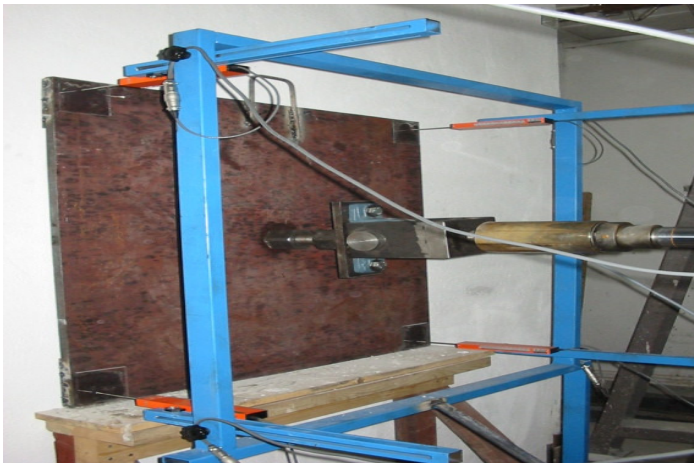

Figure 12. The location of loading plate and LVDTs.

In the application of ANSYS, potential fracture regions occurred in the element were determined by Von-Misses stress analysis. Von-Misses stress distributions are given in Figure 11. When Von-Misses stress distribution of MW under maximum load is examined, it can be seen that the maximum stresses occurred in loading region and supports.

Experiment and Its findings

Out of plane deflections formed in MW were measured with LVDTs placed in bottom and top edges of front and back of the wall together with loading plate edges present in the front and the back. The sign of load and deflection was accepted as (+) when the wall edges were under pressure (Figure 12). The load-deflection relationship obtained at the end of the experiment is given in Figure 13.

When period curves are investigated

The first wall crack under out of plane cycling load occurred under 45 kN within the elastic limits and a deflection was 2.0 mm at the time of crack, The power consumption occurred at 65 kN in MW and the deflection was 4 mm under this load, It was observed that there was a rapid decrease in the load-carrying capacity of the wall after it reached at this point, the fracture load barely reached 55 kN after 65 kN periods and the deflection at the time of fracture was 6 mm.

The deflection values in MW which was subjected to cycling out of plane loading are given in Table 2. The crack design occurred under cycling out of plane load in MW is given in Figure 14 and 15.

When the figures that show crack design are examined;

- It can be said that the behaviour of out of plane loaded masonry wall resembles that of reinforced concrete slab floor, out of plane wall load reaches to the edge supports by spreading in two directions,
- Consumption of strength and fracture occurs at the time of loading that wall edges try to tensile, wide cracks occur parallel to vertical edge lines in wall edges and this situation occurs due to enforced disconnection of wall plane from edge supports.
- Both length and thickness of cracks on the wall edges and on the wall surface increase as the load reaches the values more than 45 kN,
- It was observed that main fracture cracks formed from the center of loading plate to the edges and in a diagonal shape.

EVALUATION

When Figure 9 which shows ANSYS application concerning the strength behaviour of MW subjected to cycling out of plane load and Figure 13 which shows the experimental result are investigated, the first crack load and the fracture load in both of the applications were at 45 and 65 kN, respectively. Moreover, after 65 kN fracture load, the load of the wall barely reached 55 kN and the deflection for 45 kN first crack load was 2 mm whereas that of 65 kN fracture load was 4 mm in both of the situations. As a result, it

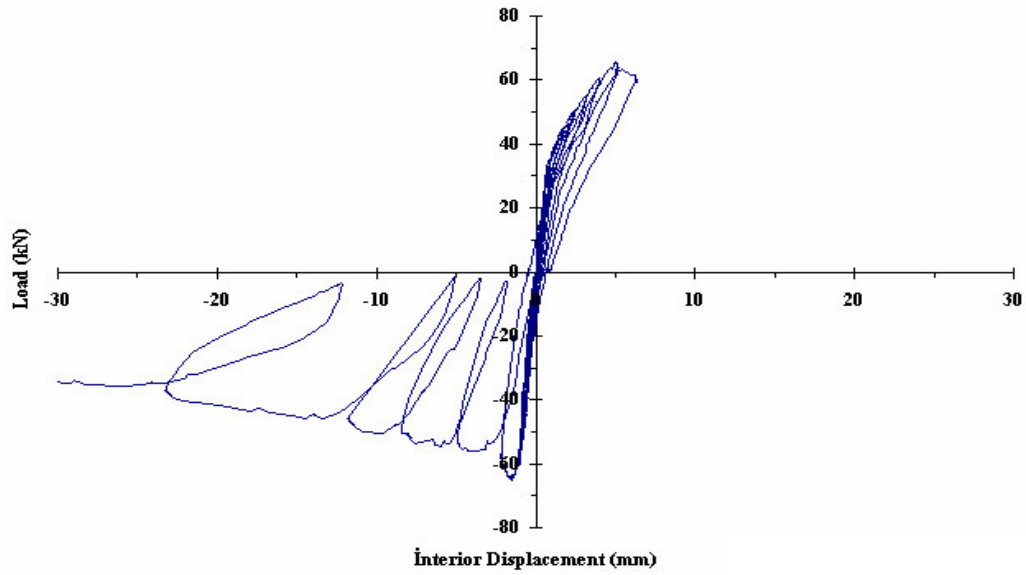

Figure 13. Load-deflection relationship.



Figure 14. The cracks occurred at the front face of MW under out of plane cycling load.

Table 2. The deflection values in MW.

Period No	Horizontal load (kN)	Displacement (mm)		Observed behaviour
		Out	In	
1.1	10	-0.3	0.3	-
1.2	-10	0.1	-0.1	-
2.1	20	-0.4	0.4	-
2.2	-20	0.4	-0.3	-
3.1	30	-0.6	0.7	-
3.2	-30	0.6	-0.4	-
4.1	40	-0.8	1.2	-
4.2	-40	0.8	-0.6	-
5.1	45	-1.0	1.7	The first crack occurred at 15 cm below left back support of side wall.
5.2	-45	1.1	-0.7	The first crack occurred at 15 cm below left back support of side wall.
6.1	50	-1.3	2.3	The second crack occurred at approximately 6-7 cm below left back support under this load and the crack moves towards wall under this continuing load. As the load reaches these values, both the lengths and thicknesses of the cracks formed at the edges and on the surface of the wall increased.
6.2	-50	1.4	-0.8	The number of cracks increased. Approximately 17 cracks occurred.
7.1	55	-1.7	3.1	Thin cracks below the front and back left support under 55 kN move towards each other and those on the left side wall of the sample under 50 kN move towards in the direction of front end back correct.
7.2	-55	1.6	-0.9	Deep, horizontal and inclined cracks occurred towards the middle of right and left side wall. These cracks continued on the front and back surfaces of the wall by getting deep.
8.1	60	-2.2	3.7	It was seen that the fracture of the wall formed at the edges and in the plane of the wall under tensile. It was concluded that "out of plane loaded wall will fracture towards "out of construction" under this behaviour.
8.2	-60	2.5	-1.1	The behaviour observed at + 60 kN similarly formed at this period, too.
9.1	65	-3	4	After reaching $F_u = 65$ kN which corresponds to power consumption, there was a rapid decrease in its load carrying capacity and the wall emptied the load on it similar to strength fracture behaviour.
9.2	-65	3.4	-1.6	Horizontal cracks occurred on the front surface and left side surface edges of the wall.
10.1	55	-4.5	6.2	Displacements and cracks continued.
10.2	-55	6.5	-3	Displacements and cracks continued.
11.1	40	-12.5	14	Displacements and cracks continued.
11.2	-40	13	-18	Displacements and cracks continued.
12.1	30	-28	20	Displacements and cracks continued.
12.2	-30	29.5	-31	Displacements and cracks continued.



Figure 15. The cracks occurred at the back face of MW under out of plane cycling load.

can be said that ANSYS analysis coincides completely with the results of the experiment.

The displacement values of MW under cycling out of plane load showed that the maximum displacement was observed as 4 mm at the uppermost horizontal plane in the middle of the wall and decreased through basic connection beam. According to these results, it was concluded that the maximum displacement value, the position and the displacement change of MW loaded with cycling out of plane load can be determined by ANSYS analysis.

In the results of ANSYS application, the stress distribution of MW became dense on loading region and supports. According to experimental results, the first cracks occurred in these regions, that is where the stresses became dense, then diagonal cracks occurred from loading regions through supports depending on the load increment. In such a situation, the crack design observed as a result of MW experiment can be determined as dense stress regions by ANSYS application.

THE REFLECTION ANSYS DATA FOR APPLICATION

ANSYS application gives very close results to experimental results in the determination of strength, displacement and stress distributions of masonry walls loaded with out of plane cycling load. These values can be used to determine the required data for the project planning and analysis of masonry constructions. Mechanical behaviours such as ductility, rigidity, energy consumption of masonry construction can be calculated by using displacement values especially under first crack and fracture loads.

MW application strength results of ANSYS are given as; the first crack was 45 kN and the displacement was 2 mm under this load, the fracture load was 65 kN and the displacement was 4 mm under this load. The ductility of MW by using these values is given as

follows equation (1):

$$\mu = \frac{4 \cdot 0}{2 \cdot 0} = 2 \cdot 0 \tag{1}$$

Its rigidity, on the other hand is given according to load-displacement equation;

Rigidity according to the first crack is equation (2):

$$\Delta i_{\varphi} = \frac{45}{2 \cdot 0} = 22 \cdot 5 \tag{2}$$

Rigidity according to the fracture is equation (3):

$$\Delta i_k = \frac{65}{4 \cdot 0} = 16 \cdot 25 \tag{3}$$

The energy consumption capacity is calculated as 320 kNmm in terms of the magnitude of related area from load-displacement graph (Figure 16).

As it can be seen, ductility, rigidity and energy consumption of the wall can be determined by using the data obtained from ANSYS application of MW under cycling out of plane load.

RESULTS

In this study; determination of mechanical behaviours of

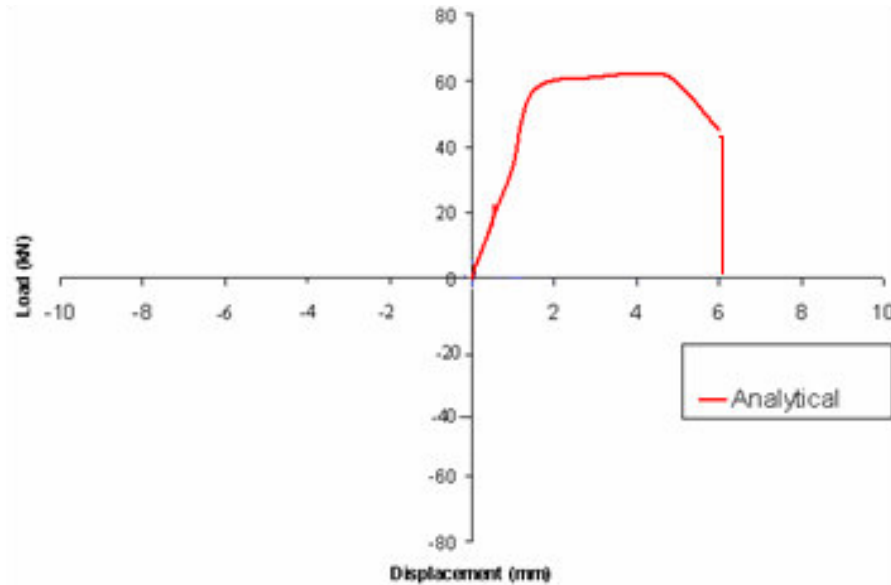

Figure 16. Energy consumption capacity of MW.

masonry walls under out of plane cycling loads with ANSYS programme was investigated. For this reason, the constructed MW was subjected in one-to-one scale and in its real dimensions to ANSYS analysis, then the wall having same properties was constructed in the laboratory, experimented under out of plane cycling load and their strength, displacement and stress distribution results were compared. According to the results, it was determined that the values of strength, displacement and stress distribution of MW loaded with cycling out of plane load can be calculated with ANSYS programme. Moreover, it was shown that ductility, rigidity and energy consumption capacities of MW can be calculated by using the results of ANSYS.

ACKNOWLEDGEMENT

The authors are greatly indebted to Selcuk University Scientific Research Foundation for providing a financial support (project numbers: BAP-06401066).

REFERENCES

- Abruzzese D, Miccoli L, Yuan J (2009). "Mechanical Behavior of Leaning Masonry Huzhu Pagado" *J. Cult. Heritage*. pp.480-486.
- Begimgil M (1991). "The Effect of Additives on the Shear Strength of Brick Masonry Wall under Biaxial Loading". *Asia-Pacific Conference on Masonry*, Singapore.
- Döndüren MS (2008). "The Effect of wall and cast mortar with improved binding property on the mechanical behaviour of out of plane loaded brick walls", Selcuk University, Graduate. School of Natural and Applied Sci. PhD Thesis, Konya.
- Fathy M, Planas J, Sancho M (2008). "A Numerical Study of Masonry Cracks" *Eng. Failure Analysis* pp.675-689.
- Gabor A, Bennani A, Jacquelin E, Lebon F (2005). "Modelling Approaches of The In-Plane Shear Behaviour of Unreinforced and FRP Strengthened Masonry Panels." *Composite Structures* pp.277-288.
- Gabor A, Ferrier E, Jacquelin E, Hamelin P (2005). " Analysis and Modelling of The In-Plane Shear Behaviour of Hollow Brick Masonry Panels" *Construction Build. Mater.* pp.308-321.
- Hamous S, McGinley M, Mlakar P, Terro MJ (2002). "Out-of-plane behavior of surface- reinforced masonry walls. *Construction Build Mater.* 16: 341-351.
- Hendry AW (1990). "Structural Masonry". MacMillan Education Ltd. Hong Kong.
- Kanit R, Atımtay E (2006). "Experimental assesment of the seismic behavior of load-bearing masonry walls loaded out-of-plane". *Turkish J. Eng. Environ. Sci.* 30: 101-113.
- Mallardo V, Malvezzi R, Milani E, Milani G (2007). "Seismic Vulnerability of Historical Masonry Buildings: A case Study In Ferrara" *Eng. Structures* pp. 2223-2241.