

Full Length Research Paper

Attempt of simulation of models to predict the disinfection efficacy of an UV disinfection reactor and kinetic study of inactivation of selected bacteria of *Pseudomonas aeruginosa* in a laboratory UV device

Mounaouer BRAHMI* and Abdennaceur HASSEN

Water Research and Technology Center, University Tunis Carthage, Soliman 8020, Tunisia.

Received 17 June, 2013; Accepted 17 March, 2014

The aims of this paper were to propose a modeling system of water UV disinfection, establish the influence of UV doses on the kinetics of disinfection, study UV-resistant strains of *Pseudomonas aeruginosa*, and improve the performances of this multipart process. The UV disinfection should inactivate pathogenic microorganisms and improve the hygienic quality of water. A comprehensive treatment in considering the mathematical aspect to model the UVc disinfection of water was achieved. A complete mathematical description of the inactivation kinetics is developed and showed two successive stages, a fast and a low one. Similarly, a mathematical model describing fluid flow and concentration of the microorganisms inside a UV reactor is developed. Modeling the kinetic and the UV lamp ray emission using some empirical approaches might increase the efficiency of UV disinfection and improve its performance. This study shows an improvement of the microbial inactivation rate of about 49% for the selected pathogenic resistant bacteria of *P. aeruginosa* (S3), and in considering perfectly mixed water flowing into the UV reactor.

Key words: Disinfection, UV₂₅₄, modeling, pathogenic microorganisms, performance.

INTRODUCTION

Disinfection of potable and wastewater using additives like chlorine, ozone or silver has a long tradition (Christoph, 2006). However, these treatments can result in the formation of disinfection by-products which are harmful to humans (Oparaku et al., 2011). Additionally, certain microorganisms are particularly resistant to chemical disinfection. Treatment with UV radiation offers a way out, since it does not involve chemicals, producing very few by-products as compared to chemical methods,

while not altering taste or chemical composition of the water. For this reason, water treatment with ultraviolet radiation becomes increasingly important and has received wide recognition as an important contribution to the protection of public health (Weinberg et al., 2002). The knowledge acquired in this field demonstrates that the use of UV for disinfection is a fast, efficient, safe and cost-effective process (Meiting et al., 2009). It has been used for many years in several countries to disinfect the

*Corresponding author: E-mail: brahmounaouer@yahoo.fr. Tel: +216-79-325-802. Fax: +216-79-325-802.

water (USEPA, 2003b; Clancy et al., 2000).

Disinfection reactors that employ ultraviolet (UV) radiation inactivate pathogenic microorganisms by altering their genetic material, thereby hindering subsequent replication. The efficiency with which UV disinfection reactors are able to inactivate microorganisms is dependent on the hydraulic characteristics of the reactor, the fluence rate distribution within the reactor, and microbial inactivation kinetics or UV dose-response behavior of the target microbial pathogen(s) (Zorana et al., 2008). However, microorganisms have evolved repair mechanisms and can reactivate, once their DNA is partially denatured. Visible light and time may have a positive influence on this process known as reactivation. UV light is electromagnetic radiation, which disinfects water by damaging the genetic material of microorganisms.

Lesions in the form of pyrimidine dimers are induced in the genomic DNA or RNA of microorganisms (Sinha and Häder, 2002), preventing normal replication, which effectively inactivates exposed microorganisms. This is justified when the water to be treated must fulfill certain things to obtain an optimal effect of UV irradiation. Physicochemical parameters such as water turbidity, hardness, suspended solids, iron, manganese, humic acids are disruptive factors of UV disinfection. Substances in water weaken the transmission rate, and deposits may also tarnish the UV reactor and taints the tubes of quartz protecting the UV lamp (Sellami et al., 2003). The regular change and cleaning of UV quartz sheath lamps provide a good ray permeability thus good distribution. Besides, several parameters can also influence the rate of microbial inactivation such as the UV dose applied, the stability of disinfectant, the contact time, the pH and the temperature of water, and the number and type of microorganisms in water (in terms of resistance) (Hassen et al., 1997). The relationship between these parameters can be evaluated by means of analytical measurements in the laboratory.

However, because of the complex dynamics governing this process, only certain parameters such as the UV dose, the contact time and the content of suspended solids in water can be studied at laboratory scale to establish laws monitoring the UV disinfection. To better explain the process of inactivation, some disinfection kinetic models have been proposed in the literature to validate the experimental results, beginning from the simplest model UV water purification lamps produce UV-C or germicidal UV, with radiation of much greater intensity than sunlight. Almost all of a UV lamp's output is concentrated in a 254 nm region in order to take full advantage of the germicidal properties of this wavelength. Most UV purification systems are combined with various forms of filtration, as UV light is only capable of killing micro-organisms such as bacteria, viruses, molds, algae, yeast and oocysts such as *Cryptosporidium* and *Giardia*. UV light generally has no impact on chlorine,

volatile organic compounds (VOCs), heavy metals and other chemical contaminants.

Nevertheless, it is probably the most cost-effective and efficient technology available to homeowners to eliminate a wide range of biological contaminants from their water supply. This study was therefore carried out to investigate the effectiveness of UV light for wastewater disinfection (Oparaku et al., 2011).

This is justified when the water to be treated must fulfill certain physico-chemical conditions to get a good effect of UV irradiation. Physico-chemical features such as water turbidity, hardness, suspended solids, iron, manganese, humic acid content are disruptive causes of UV disinfection. Substances in water weaken the transmission rate, and deposits may also tarnish the UV reactor and taints the tubes of quartz protecting the UV lamp (Sellami et al., 2003). The regular change and cleaning of UV quartz sheath lamps provide a good ray permeability thus better distribution. Besides, several parameters can also influence the rate of microbial inactivation such as the UV dose applied, the stability of disinfectant, the contact time, the pH and the temperature of water, and the number and type of microorganisms in water (in terms of resistance) (Brahmi et al., 2013). The relationship between these parameters can be evaluated by analytical measurements in the laboratory. However, because of the complex dynamics governing this process, only certain parameters such as the UV dose and the contact time can be studied at laboratory scale to find out laws monitoring the UV disinfection.

On the other hand, the optimization of the process of water disinfection by UV irradiation can be tried by several approaches. The first is a technological approach that concerns the choice of the different units of the system; the second is an economic approach that concerns optimisation of the costs. The mathematical approach is helpful in modeling and lessens expensive experiences by reducing the operation of controls.

The biotechnical modeling presents great difficulties. Indeed, it needs to involve a multidisciplinary group of experts in biology, chemistry, mathematics, automation, etc. Whereas, it is to be realized that, even if the models are established, the process is likely to be complex.

This research was aimed at first, understanding and evaluating the germicidal UV water disinfection, secondly to establish the influence of UV doses on the kinetics of disinfection, to study UV-resistant strains of *Pseudomonas aeruginosa*, and thirdly to establish and diagnose a mathematical model for simulation and improvement of the UV_C water disinfection.

MATERIALS AND METHODS

Types and characteristics of treated wastewater used

The treated wastewater samples used in this study were collected at the outlet of a pilot wastewater treatment plant (WWTP)

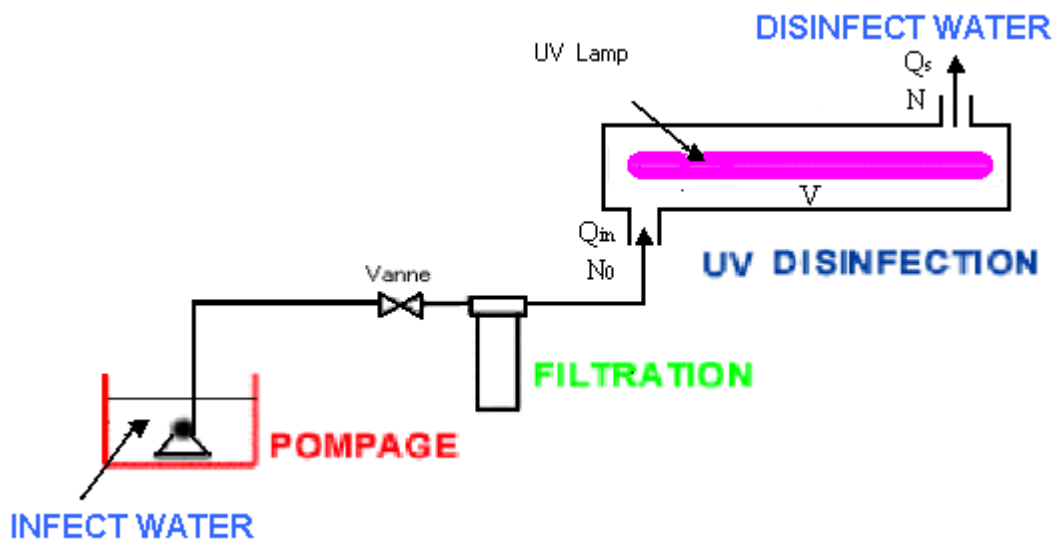

Figure 1. Synoptic diagram of the UV pilot scale disinfection system.

belonging to the Water Research and Technology Center, Tunisia. The pilot WWTP is connected to the sewerage network of the city of Tunis that includes a process capacity of 150 m³ per day. It is composed of 4 treatment lines operative in parallel: a trickling filter, rotating biological discs, and a land and lagoon optional filter. Throughout disinfection tests, the physico-chemical characteristics of the wastewater treated by the trickling filter did not show considerable change. The values fluctuated between 47 and 49% for ultraviolet light transmission, 15 to 47 mg/L for total suspended solids (TSS), 20 to 29 mg/L for biochemical oxygen demand (BOD₅) and 90 to 102 mg/L for chemical oxygen demand (COD).

Experiments in a batch laboratory irradiation device

The laboratory UV device used in this study has previously been described by Hassen et al. (1997). A low pressure UV-C lamp is used. This lamp emitted an average intensity of about 7 mW.cm⁻². In addition, all bacterial strains of *P. aeruginosa* studied were cultivated to a mid-log phase at 37°C in 20 mL of nutrient broth. Each culture was centrifuged at 5,000 rpm/min for 15 min and the pellet was washed twice with sterile distilled water. The washed pellet was resuspended in 10 mL sterile distilled water. Test organisms were then seeded separately, into 20 mL of sterile wastewater with UV transmittance of 50%, to give a viable cell count of approximately a 10⁵ to 10⁶ colony-forming unit (CFU)/mL, the same mean count as that in the secondary wastewater suspension. The test organisms were then exposed to the UV-C light for various times ranging from 2 to 90 s.

UV pilot equipment

This study was carried out in a wastewater treatment pilot plant equipped with a monolamp UV reactor supplied by Katadyn (Katadyn Produkte AG, Wallisellen, Switzerland). This UV reactor has a useful volume of 2 L and constituted a stainless cylindrical container ran continuously during the study. A low pressure mercury vapor discharge lamp (length = 680 mm, diameter = 18 mm, power of UV emission at 254 nm = 65 W) was inserted into a quartz sleeve for mechanical protection and sealing. Every month the sleeve was cleaned mechanically with a dilute hydrochloric acid

solution to prevent a filthiness of the lamp. A selective detector for UV (253.7 nm) joined to a radiometer (Vilbert- Lourmat, Norme la Vallée, France) allowed the measure of UV intensity at the emerging of the quartz sleeve. The applied UV dose (or fluence) is traditionally characterised in terms of the energy per surface area or mJ.cm⁻², and is a product of the average UV intensity (fluence rate) (mW.cm⁻²) multiplied by the exposure time in seconds. UV is attenuated by UV-absorbing substances in water, which reduce the transmittance of UV through water and consequently impact the dose received by microorganisms. The UV transmittance of water to be disinfected is therefore taken into account when calculating the average UV intensity applied to water. The synoptic diagram of the UV pilot-scale disinfection is represented in Figure 1.

Costache et al. (2001) showed that it should be better in real conditions of the UV disinfection to supply the lamp with the strongest possible electric current. The schematic concept of the UV irradiation is represented in Figure 2.

A decrease of the water debit at the entry of UV reactor is linked to an improvement of the removal of pathogenic microorganisms. Theoretically, the time of UV exposure can vary from 1 to 300 s, but often a time of exposure of 7 to 15 s proved to be enough to guarantee a satisfactory abatement (Hassen, 1998).

For efficient water disinfection, it is essential that all parts and each volume of the water receives sufficient UV ray exposure of at least 88 mW.s.cm⁻² (at 253.7 nm and water transmission superior to 45%) to reduce human pathogens (fecal streptococci and fecal coliforms) by at least 3 logs (Hassen et al., 2000). The homogeneity of the flow pattern and the radiation field may have critical effects on disinfection.

Bacterial strains selected for UV-disinfection study

Many pathogens are responsible for waterborne diseases. Despite the development of molecular methods, currently it is not always possible to detect comprehensively all micro-organisms in a water sample. Therefore, most studies in this area have mainly focused on the number of fecal indicator bacteria (total coliforms, fecal coliforms and fecal streptococci in general) to estimate the population of pathogens. However, recent studies showed that the species of *P. aeruginosa* seems to be a valid sanitary indicator for recreational waters (Brahmi et al., 2010). This parameter is actually

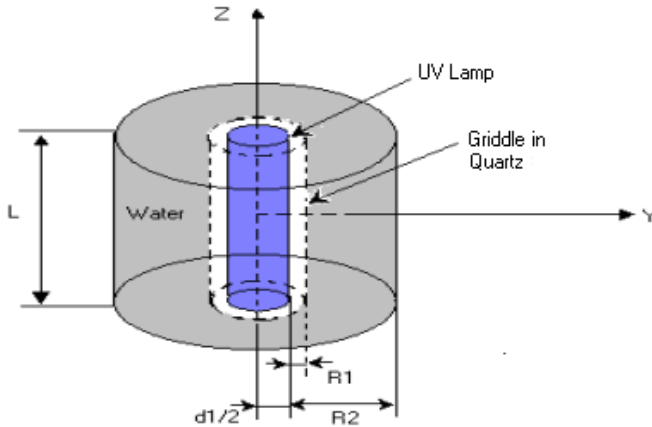

Figure 2. Configuration of the UV irradiation disinfection system. Width: L , d_1 , R_1 and R_2 are length of the reactor approximated to the length of lamp, diameter of the lamp, radius of the quartz sleeve and the interior radius wall of the irradiation room, respectively.

used as a criterion in the regulation of wading and swimming pools. Moreover, the absence of *P. aeruginosa* is important not only for its role as an indicator, but also because it is an opportunistic pathogen of which the transmission is often associated with water. Its use for evaluating the effectiveness as a treatment of UV-disinfection seems therefore reliable. Consequently, its kinetics of inactivation by UV irradiation has assumed the same fate as for all other less resistant pathogens.

For all the above reasons, a collection of three strains of *P. aeruginosa* includes strains of *P. aeruginosa* ATCC 15442 [PA = S1] (provided by DIFCO, laboratory POBOX 331058, Detroit M 48232-7058 USA). The other two strains were isolated from wastewater and treated without a repetitive sequential dose of UV (S2 and S3). All the strains were grown in the laboratory in nutrient broth (Institute Pasteur Production).

On the other hand, we defined the UV-C dose received by the microbial cells as the product between the time of exposure (sec) to UV-C and the intensity emitted by the UV lamp ($\text{mW}\cdot\text{cm}^{-2}$).

The kinetic models used for UV-C inactivation

These kinetic approaches are based on experimental studies using: a laboratory disinfection device; 3 selected strains of *P. aeruginosa* grown on a nutrient agar (Pasteur Institute Production, Tunisia); and different simulation models, from the simplest model of Chick-Watson reduced to first-order kinetics, to complex models such as the modified Chick-Watson model.

The model of Chick-Watson is used primarily to express the kinetics of disinfection with chemical disinfectants (Trussell and Chao, 1977; Roustan et al., 1991). The first-order kinetics is expressed as follows:

$$\frac{dN}{dt} = -K \times C^n \times N \quad (1)$$

The integration of this expression gives:

$$N/N_0 = e^{-KC^n t} \quad (2)$$

C is the concentration of disinfectant used; K is a coefficient reflec-

ting the specific case of disinfecting lethality potential; n is the coefficient of dilution, which is a function of disinfectant and pH of water (the value of n is usually close to unity); and t is the exposure time to disinfectant.

In the case of UV-disinfection, an amendment to this model was made by replacing the concentration of chemical disinfectant (C) with the intensity of UV radiation, as proposed by Haas (1999). The disinfection kinetics could be rewritten as follows:

$$dN/dt = K \times I^n \times N \quad (3)$$

The integration of this expression gives

$$N/N_0 = e^{-KI^n t} \quad (4)$$

Changing the logarithmic form and using a linear regression, the kinetic parameters (K and n) of the latter expression could be determined as follows:

$$\text{Ln} \left[-\text{Ln} \left(\frac{N}{N_0} \right) \right] = \text{Ln}(K) + n \cdot \text{Ln}(I) + \text{Ln}(t) \quad (5)$$

When $n < 1$, the disinfection process is more controlled by the contact time than by the UV dose. When $n > 1$, the UV dose takes precedence over the contact time in the control of the process (Leahy et al., 1987).

RESULTS AND DISCUSSION

Behavior of *P. aeruginosa* strains after UV irradiation

P. aeruginosa strains issued from an environmental origin (S2 and S3) tested were isolated from wastewater and submitted to a sequential and alternate treatment of 2 or 4 min of exposure to UV rays, called passage. These successive passages of 2 or 4 min exposure to UV₂₅₄ rays were performed in 90 mm Petri dishes. After each passage, the environment is enriched by a solution of 5 ml of asparagine (5 g/l) and incubated for 1 h at 37°C. Both strains tested S2 and S3 were exposed to 34 and 86 passages, respectively, and corresponding to a cumulative UV dose of 68.544 and 173.376 $\text{mW}\cdot\text{s}\cdot\text{cm}^{-2}$, respectively.

Thus, we recorded a significant resistance to UV radiation for these two strains marked by good growth and intense pigmentation (release of pyoverdine or fluorescein known as a specific fluorescent pigment released by these species in some definite circumstances).

In this sense, a study published by Hassen et al. (1997) and recently by Lesavre and Magoarou (2004), showed that the treatment of *P. aeruginosa* strains with low UV doses ($<30 \text{ mW}\cdot\text{s}\cdot\text{cm}^{-2}$) has a significant effect on the growth stimulation of these bacteria. To confirm the acquisition of UV resistance of these two strains (S2 and

P. aeruginosa (S3)

Figure 3. Inactivation of *P. aeruginosa* (strain S3 for example) according to UV dose applied before and after a prolonged exposure to UV ray. N/N_0 : Rate of inactivation of microorganisms after exposure to UV; N : Number of bacteria after the period of exposure to laboratory light; N_0 : Number of microorganisms at the instant $T = 0$ ($N_0 = 10^7$ organisms/100 ml).

S3), a kinetic inactivation study was carried out and an example of the experimental results obtained for the strain S3 is shown in Figure 3. As evident from the figure, the kinetics abatement of the strain S3 treated with UV differ significantly from that of the S3 strain of departure (not treated). Therefore, the sequential UV treatment of the starting strains S3 induced a significant resistance to UV radiation.

Inactivation kinetic of *P. aeruginosa*: UV dose-response

Several mathematical relationships have been developed to describe bacterial responses to UV irradiation. UV dose plays an important role in all bacterial inactivation models for UV irradiation (Qualls et al., 1989).

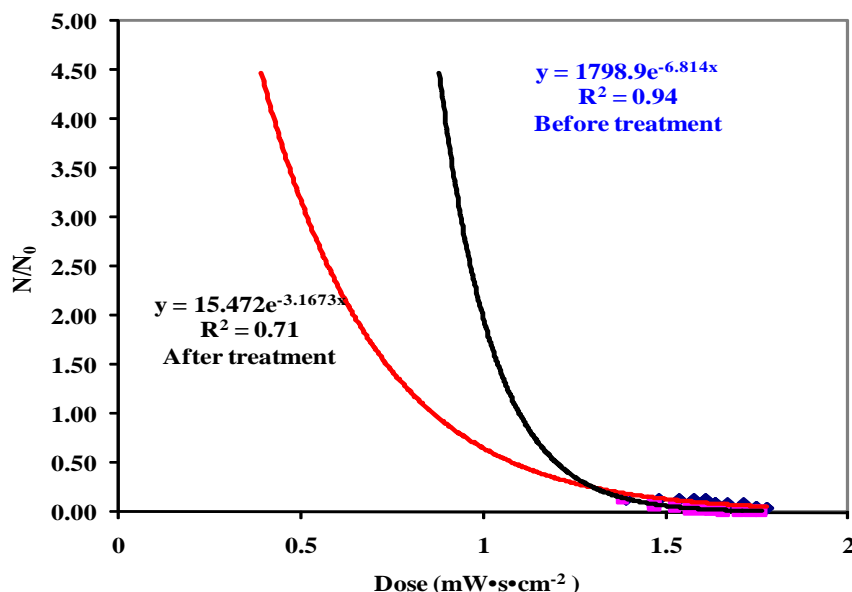
In this study, the curve commonly illustrating the kinetics of inactivation usually showed a significant gap between the experimental points and those simulated by the model in the case of studied strain S2 of *P. aeruginosa* taken as a model (Figure 4a). In the same way, the determination of sum of squares of residuals (SSR), a representative parameter of the difference between the experimental values $(N/N_0)_{mes}$ and the calculated values of the model $(N/N_0)_{cal}$, appeared to be important to this strain ($R^2 = 0.60$, $SSR = 0.17$). Therefore, we found that the model of Chick-Watson, reduced to a

first-order kinetic with $n = 1$, showed its limits, and that the inactivation process is most often non-uniform, and does not necessarily comply, as first-order kinetics, with an exponential law (Haas, 1999; Hassen, 1998; Shayeb et al., 1998). However, the adopted experimental protocol showed a very noticeable reduction rate for low doses of irradiation. The importance of UV radiation intensity of the lamp allows a yield rate of 2 U-log to be achieved after only 2 s of exposure.

A decrease in additional U-log could not be attained, even after an exposure time of 90 s (results not shown). The application of a first order kinetic during the second stage involves the change of the model by introducing a dimensionless coefficient A , in order to reflect the decline achieved during the first fast kinetics stage (Figure 4b).

This initial abatement A is suggested and added to the common Equation 3 of the model to view and validate this empirical model at first and secondly to reflect the decrease achieved during the first fast kinetics stage. The expression of the model (4) becomes (Mamane-Gravetz and Linden, 2004):

$$\frac{N}{N_0} = A \cdot \exp(-kIt) \quad (6)$$

Where A is the initial abatement of the number of microorganisms during the contact between UV rays and

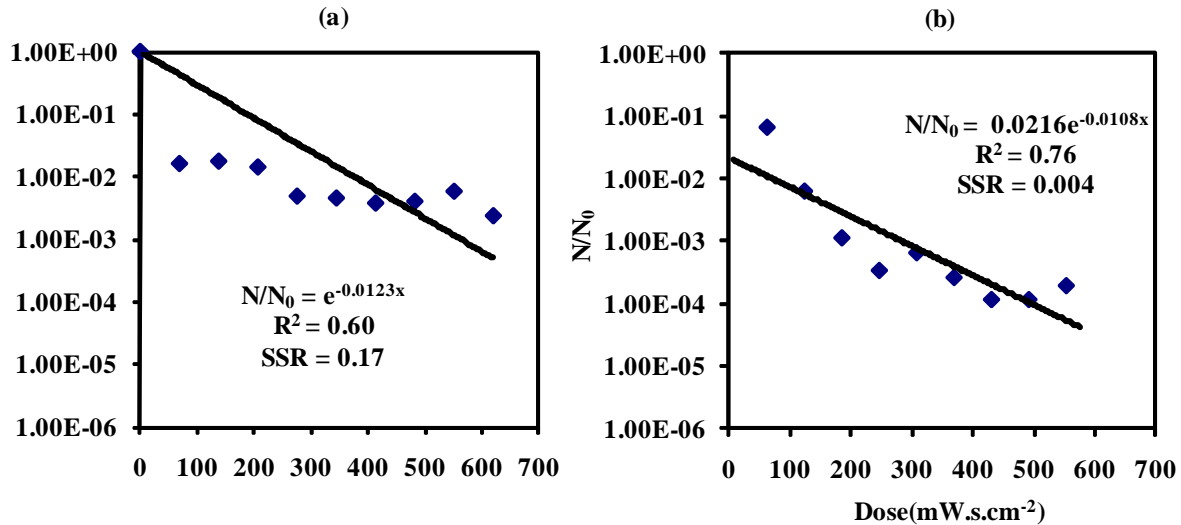

Figure 4. Study of the disinfection efficiency as a function of irradiation dose according to the models of Chick-Watson (a) and Amended chick-Watson (b), respectively. y : reduction = N/N_0 with N ; number of bacteria at the instant T ; N_0 ; Number of bacteria at the instant $T = 0$; R^2 : Coefficient of determination; Dose (mW.s.cm^{-2}) = $I \times T$ = UV intensity (mW.cm^{-2}) \times time of contact (s).

Table 1. Some examples of kinetic inactivation according to the modified Chick-Watson model.

Strain	Equation 1 (y_1)	Equation 2 (y_2)
<i>P. aeruginosa</i> ATCC15442 (S1)	$y = 0.0757 \exp(-0.0361It)$	$y = 0.03 \exp(-0.0167It)$
<i>P. aeruginosa</i> (S2)	$y = 0.0381 \exp(-0.0297It)$	$y = 0.0065 \exp(-0.0057It)$
<i>P. aeruginosa</i> (S3)	$y = 0.0611 \exp(-0.0163It)$	$y = 0.0089 \exp(-0.0018It)$

water. The parameters to identify in this case are K and A .

By working out the difference in these two cases (SSR and R^2), the values obtained depending on the model of Chick-Watson in its modified form were smaller ($SSR = 0.004$) than those calculated using the same model in its initial form ($SSR = 0.17$). In the same way, the correlation coefficient R^2 obtained using the amended model of Chick-Watson were generally higher ($R^2 = 0.76$) than those obtained using the same model in its original form ($R^2 = 0.60$) (Figure 4). Thus, we found that the adjustment of the same model when considering an initial reduction describes quite well the kinetics of disinfection for most of the studied strains.

On the other side, the results of Sellami et al. (2003) showed that the first instants of UV exposure (2 to 10 s) are capital for bacterial inactivation where the UV lethal effect is critical and destructive, and later added UV exposure would be of less damage to microorganisms, and surviving numbers slowly decline.

The end of the kinetic curve of UV inactivation has a tailing phase due to UV resistance of the microorganisms and to experimental conditions, such as suspended solids content, turbulence in the reactor, which may block the UV irradiation.

Indeed, the microbial inactivation speed is important in this first interval of time. The increase of the contact time with UV rays beyond this interval has no significant effect on inactivation, and the speed of bacterial inactivation becomes slow and constant. According to the UV dose applied, two types of inactivation prevail: a high rate of inactivation with weak UV doses, and a low rate of inactivation with fairly doses.

All these factors favour the idea of a kinetic multimodel of microbial inactivation: a first model with rapid dynamics that describes the kinetics of disinfection during the first instants of UV exposure, and a second model with slower dynamics. Table 1 shows examples of the two modes of UV inactivation according to the modified model of Chick-Watson (with the initial reduction A , equation 6) for some selected bacterial strains.

Each examined strain is characterized by two equations y_1 and y_2 . For a given microorganism, the instant of encounter between the representative curves of equations (y_1) and (y_2) is often considered as an instant of commutation between the first high-rate dynamic (y_1) and the second low-rate dynamic model (y_2).

Figure 5 illustrates an example of the experimental results according to the curve of adjustment of the model.

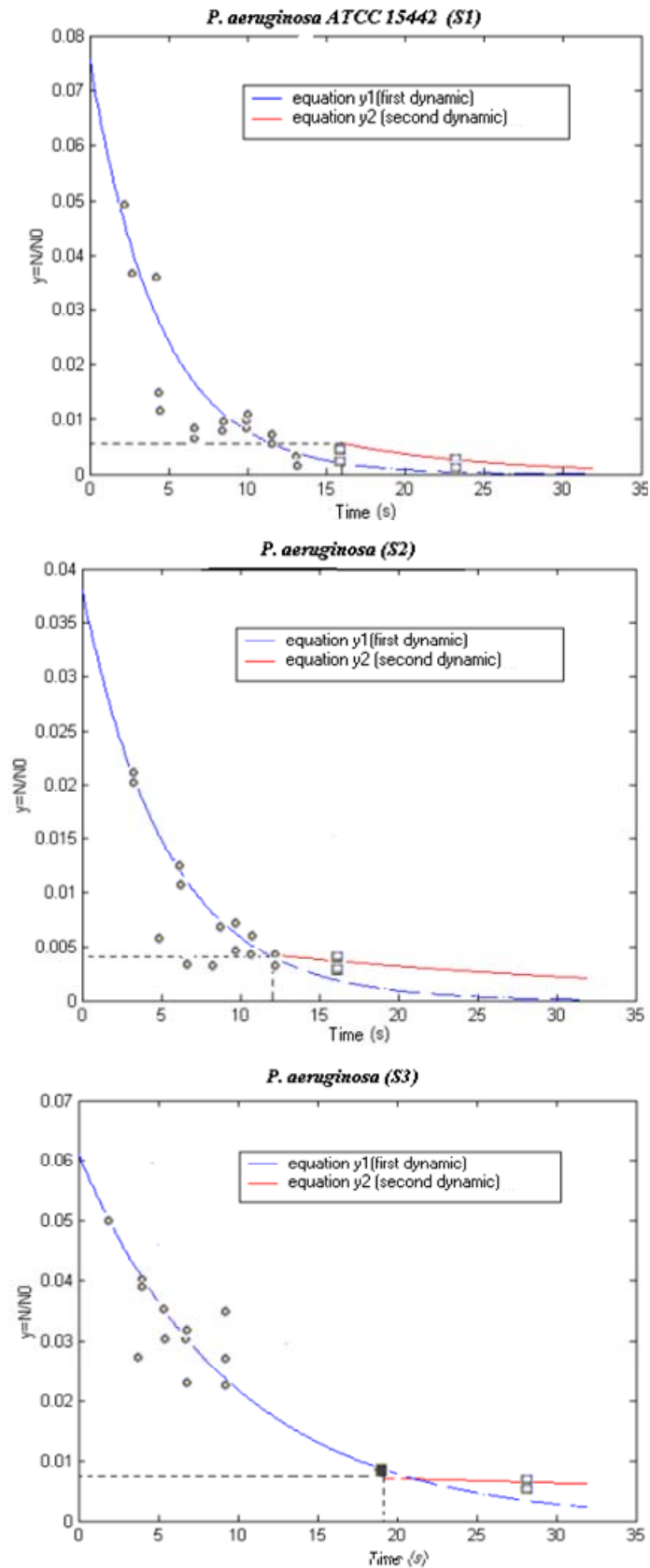

Figure 5. Some kinetic examples of microbial inactivation adjustment according to the modified Chick-Watson multimodel.

The variation of the kinetics of disinfection follows the UV irradiation dose. The switching between equations 1 (y_1) and 2 (y_2) depends on the genera and the type of microorganism, and on the amount of UV applied; and so, is dependent on time if the UV ray intensity is considered constant ($I = \text{Constant} = 6.3 \text{ mW.s.cm}^{-2}$).

On the other hand, the experimental batch study reported by Hassen et al. (2000) using some selected bacteria, and the modified model of Chick-Watson showed that the kinetics of bacterial inactivation varied according to the UV dose applied. The first instants (2 to 10 s and corresponding to average doses of 10 and 80 mW.s.cm^{-2}) appeared as a controlling factor. It is assumed that outside the effect of dose, an effect of shock is needed to assure inactivation at least for certain microbial species.

Difficulties of modeling mercury low-pressure vapor discharges lamp

The energetic flux emitted by the mercury vapor lamp is a complex function depending basically on the two factors, electric current and time. Further, these functions depend on the geometric characteristics of the lamp, the rare gas used, the pressure within the lamp and the external temperature of the lamp. These variables are complicated and depend on the hysteretic and on the internal dynamic ones (dynamic conductance of the lamp) of which equations of variation are not precisely determined, and diagrams are no monotones. These factors complicate the development of the general model characterizing the variation of emitted flux or the arc tensions according to the arc current and time (Zitouni et al., 2011). Results and relationships between all these variables are determined using an empirical approach.

To determine a relationship between the electric powers consumed by a germicidal low-pressure mercury lamp, a bibliographic research showed that in a general way, 50 to 60% of the electric power consumed by the germicidal low-pressure mercury lamp is transformed into UV radiation. The rest is scattered by the effects of collision, excitation, diffusion, thermal conduction (Porras, 1998). The tension of the arc is the product of the arc current and conductance that depends on a nonlinear function of the current, which are the exact relationships under investigation.

The lack of a real function relating tension current or current-emitted flux, leads us to use the electric power consumed as follows:

$$F_0 = 0.55P \quad (7)$$

Where, F_0 and P are the UV flux emitted and the electric power consumed by the UV lamp, respectively.

We estimated in Equation 7 that 55% of the electric power

power consumed is transformed into emitted flux. This value of 55% is often used in the literature (Porras, 1998; Sarroukh et al., 1999).

Optimization of the UV disinfection

Generally, the UV disinfection of water takes place with a variable flow and the most possible favorable surrounding conditions; in addition, biologists are expected to work with constant UV intensity (constant I) except for uncontrolled variations inherent to the environment, for example, temperature.

This study showed that temperature increase improved the effectiveness of UV irradiation emission and thus improved bacterial inactivation (Brahmi et al., 2012). As mentioned above, (i) the model of Chick-Watson modified with an initial reduction A represented correctly the experimental result (ii) the kinetics of UV inactivation include two types, the first is a rapid dynamic and high inactivation rate and the second a slow dynamic and low inactivation rate that stabilize through time. This approach allowed us to affirm the efficiency of UV irradiation decreases throughout the time. This decrease results to a constant UV irradiation during disinfection. The idea is to increase as much as possible the energy during the first instants of irradiation that are determinant for the bacterial inactivation, and in a second phase to lower the irradiation dose as the efficiency of the UV decreases.

Influence of water flowing on average UV irradiation

Water specialist researchers in general use a probe that measures UV irradiation on the surface of the quartz sleeve. This UV emission corresponds to the strongest radiation in the irradiation room if we ignore the effect of existing air between the quartz sleeve and the surface of the lamp. As shown above, the width of the water layer causes a serious decrease of UV radiation (optical path), and therefore the use of ray intensity (I) mentioned by the probe is not efficient for modeling the UV reactor. In this study we calculated the average radiation in the irradiation room. This average radiation depends physically on the water flow.

Indeed, there are two limit types of flow, the piston and the perfectly mixed. For piston flow, all fluid molecules cross the chamber of reaction at the same speed in parallel trajectories. In this layered or laminar flow, there is neither mixture nor dispersion; all particles have same residence time equal to the average time of hydraulic stay. The response is therefore the realistic reproduction of the excitation. For a perfectly mixed flowing, the entering fluid is scattered instantaneously in the entire volume of the reactor by an intense agitation. The average dose prevailing in the reactor is defined as the report between the total energy deposited per second in

the interior of the reactor and the fluid volume that crosses the entire reactor chamber per second. Although, the fluid volume depends on the speed of fluid circulation in the reactor, subsequently, calculation of the efficient radiation presume the speed of the fluid which is known. This speed depends on the type of circulation of the fluid in the reactor (Costache, 2001).

Case of piston flowing

We consider the case of reactor in the Figures 1 and 2, with a minimum and a maximum radius R_1 and R_2 , and a length L , without absorption and mixture, where the UV radiation intensity I_r depends on the distance r to the reactor axis. The speed of circulation in all points of the irradiation room (v_r) is constant and equal to the speed in the center of the reactor (v_0):

$$v_r = v_0 \tag{8}$$

In these conditions, we can write the fraction of flow submitted to a UV radiation as:

$$I_r = \left(1 - \lambda \frac{r}{R_2}\right) \frac{F_0}{2\pi r L} \tag{9}$$

Equation (11) is equal to

$$Q_r = \frac{1}{\pi(R_2^2 - R_1^2)} 2\pi r dr \tag{10}$$

Where λ represent a constant equal to 0.1 in this case, and $F_0 = 0.55P$ the irradiation flux emitted by the source. Thus, the weighted average value of UV radiation intensity I of flow will is expressed as:

$$I_{Mp} = \int_r I_r Q_r \tag{11}$$

Or more,

$$I_{Mp} = \frac{1}{\pi(R_2^2 - R_1^2)} \int_{R_1}^{R_2} \left(1 - \lambda \frac{r}{R_2}\right) \frac{F_0}{2\pi r L} 2\pi r dr \tag{12}$$

We find after integration:

$$I_{Mp} = \frac{F_0}{\pi L} \left(\frac{1}{R_2 + R_1} - \frac{\lambda}{2R_2} \right) \tag{13}$$

For example, with the following numeric values:

$$\begin{cases} F_0 = 36W, & \lambda = 0.1 \\ R_1 = 0.00785m, & R_2 = 0.2156m, & L = 0.8m. \end{cases}$$

We find

$$I_{Mp} = 6.08mW.cm^{-2}$$

Case of a perfectly mixed flow

For a perfectly mixed flow and for the same diagram reactor (Figure 2), without absorption and mixture, but where UV radiation I_r and speed v_r depend on the r distance to the axis, it is possible to consider the UV radiation I_r in r varied as described in the equation (9). We will suppose at first the flow speed varies linearly between the center and the border according to a simple law of the same type:

$$v_r = \left(1 - \xi \frac{r}{R_2}\right) v_0 \tag{14}$$

Where, v_0 and ξ are the speed at the axis of reactor without a lamp and constant that characterizes the variation of speed as moving away from the axis of reactor.

We consider that, according to the mode of water insertion into the reactor, the speed in the center will be more important than the one in the border of reactor.

In this example, the speed in the periphery is lower than the speed in the center. In these conditions, we inscribe the fraction of the flow presented to a UV irradiation of the form (11) is equal to:

$$Q_r = \frac{1}{\pi(R_2^2 - R_1^2) v_m} \left(1 - \xi \frac{r}{R_2}\right) v_0 2\pi r dr \tag{15}$$

Where v_m is the average speed that can be related to the flow into the reactor, and its formulation is developed as follows:

$$v_m = \frac{1}{\pi(R_2^2 - R_1^2)} \int_{R_1}^{R_2} \left(1 - \xi \frac{r}{R_2}\right) v_0 2\pi r dr \tag{16}$$

Or:

$$v_m = v_0 \left(1 - 2\xi \frac{R_2^2 + R_1^2 + R_1 R_2}{3R_2(R_2 + R_1)}\right) \tag{17}$$

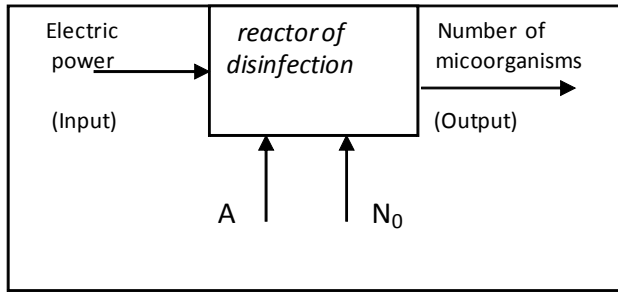

Figure 6. Block of the photoreactor in open buckle.

Therefore, the weighted average value I of UV radiation of rate of flow is written as:

$$I_{Mm} = \frac{1}{\pi(R_2^2 - R_1^2)} \int_0^{R_2} (1 - \lambda \frac{r}{R_2}) \frac{F_0}{2\pi r L} (1 - \xi \frac{r}{R_2}) v_0 2\pi r dr \tag{18}$$

We find after integration:

$$I_{Mm} = \frac{F_0 v_0}{\pi L v_m} \left(\frac{1}{R_2 + R_1} - \frac{\lambda + \xi}{2R_2} + \lambda \xi \frac{R_2^2 + R_1^2 + R_2 R_1}{3R_2(R_1 + R_2)} \right) \tag{19}$$

The weighted average value of UV radiation will be expressed as follows:

$$I_{Mm} = \frac{F_0 v_0}{\pi L (R_2 + R_1)} \frac{1 - \frac{(\lambda + \xi)(R_1 + R_2)}{2R_2} + \lambda \xi \frac{R_2^2 + R_1^2 + R_2 R_1}{3R_2^2}}{1 - 2\xi \frac{R_2^2 + R_1^2 + R_2 R_1}{3R_2(R_1 + R_2)}} \tag{20}$$

Conditions and numeric values of the reactor are as follows:

$$\begin{cases} F_0 = 36W, \quad \lambda = 0.1 \\ \xi = 0.2, \quad R_1 = 0.00785m \\ R_2 = 0.2156m, \quad L = 0.8m \end{cases} \tag{21}$$

We find:

$$I_{Mm} = 6.3 \cdot mW \cdot cm^{-2}$$

Formulation of the control problem

The objective of seeing control laws is to reduce the number of microorganisms at the exit of the UV reactor,

while acting on the energizing illumination (I) of the UV rays at the entry of the reactor in a perfectly mixed flow (Figure 6).

The problem can be posed in the following way to give a variation of UV radiation intensity I in such a way the number N of microorganisms at the exit of the UV reactor is reduced according to the following constraints:

$$\begin{cases} \frac{N}{N_0} = A \cdot \exp(-kIt) \\ I_{Mm} = \frac{F_0 v_0}{\pi L (R_2 + R_1)} \frac{1 - \frac{(\lambda + \xi)(R_1 + R_2)}{2R_2} + \lambda \xi \frac{R_2^2 + R_1^2 + R_2 R_1}{3R_2^2}}{1 - 2\xi \frac{R_2^2 + R_1^2 + R_2 R_1}{3R_2(R_1 + R_2)}} \end{cases} \tag{22}$$

$$F_0 = 0.55P$$

and $P < P_{max}$

$$P_{max} = 1.5 \text{ to } 2.5 P_n \quad (P_n = 65W)$$

According to the numeric conditions of the system (22), the model (23) becomes:

$$\begin{cases} \frac{N}{N_0} = A \cdot \exp(-kIt) \\ I = 1.75F_0 \\ F_0 = 0.55P \end{cases} \tag{23}$$

With $P < P_{max}$

For $y = N/N_0$, it is possible to express:

$$\begin{cases} \frac{dy}{dt} = -kIy \\ I = 1.75F_0 \\ F_0 = 0.55P \end{cases} \tag{24}$$

$$\text{Under } \begin{cases} P < P_{max} \\ y_0 = A \end{cases}$$

The parameters k and A are identified, using a constant intensity $I = 6.3 \text{ mW} \cdot \text{s} \cdot \text{cm}^{-2}$, according to Figure 7.

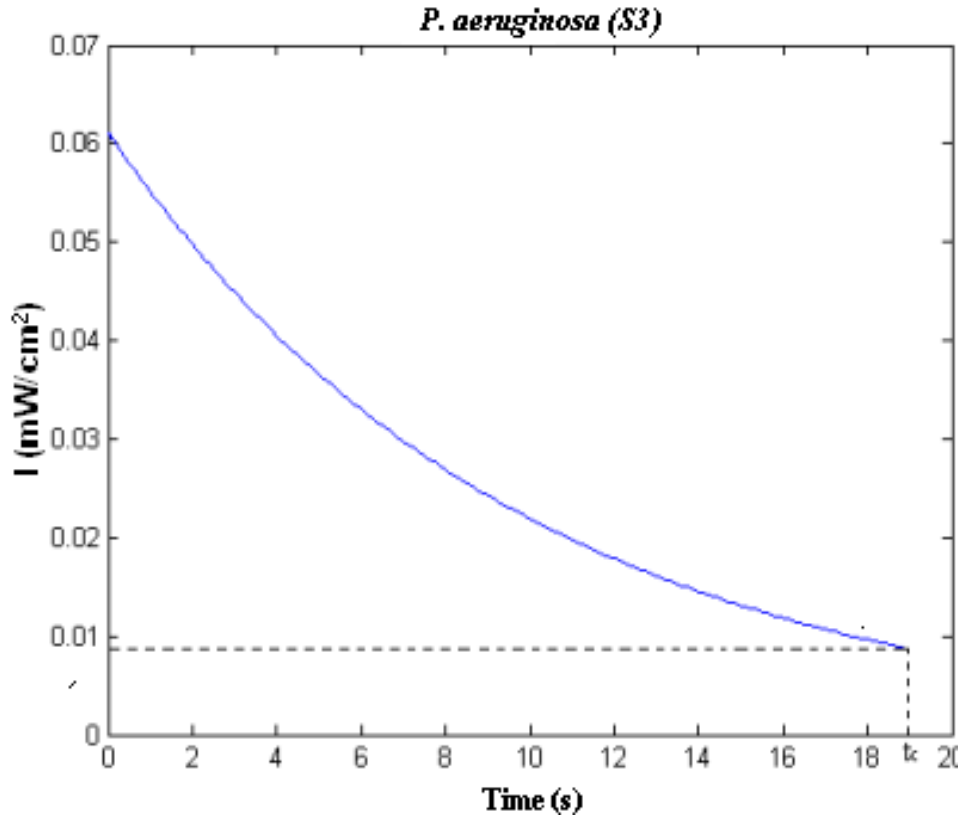

Figure 7. Variation of the *P. aeruginosa* (S3) inactivation (fast dynamics) in open buckle.

The diversity of bacteria, and therefore the large number of models needed for all these bacteria, led us to work with the most resistant strain for UV radiation: *P. aeruginosa* ATCC 15442. The analysis and the optimization of results affirmed that such UV disinfection cannot be done only during the first kinetics (rapid) and it approves an important efficiency of UV inactivation (Brahmi and Hassen, 2011).

Where $y = N/N_0 = 0.0611 \exp(-0.01631t)$

Figure 8 gives a simulation of the model (25) for an average UV intensity $I = 6.3 \text{ mW.s.cm}^{-2}$ and for the same UV dose used during the first dynamic of inactivation of *P. aeruginosa* ATCC 15442.

The duration of validity of the first dynamic (equation y_1), for the strain of *P. aeruginosa* and for $I = 6.3 \text{ mW.s.cm}^{-2}$ as it is shown in Figure 9, is $t_c = 19.04\text{s}$. Now there is a commutation toward the second dynamic (equation y_2) which will take over. To improve result gained during the active interval, from instant zero to instant t_c , it allows a commutation to reach final value y_f towards the second dynamic that will be adjusted to the last value of $y_f = N_f/N_0$ gotten at $t = t_c$. The constant time delay of this kinetic response is τ determined according to Figure 8 and it is equal to 9.7 s.

Conception of an improved control

Difficulties faced during the determination of relationships between the intensity of UV radiation, the arc tension and the arc current, in addition to the non emergence of a variable of control according to the Chick-Watson's model (Haas, 1990), made us to work with the flux emitted by the lamp and prompted us to find a way of improvement that considers the practical constraints of lamp functioning. Indeed, an increase in the UV dose and the UV radiation improves the results but leads to an increase of the lamp temperature and a risk of lamp damage; further, it will increase the losses in electric energy since the first instants of radiation are the most determinant of disinfection. Beyond this stage, the efficiency of the UV radiation decreases noticeably. This fact leads us to consider an exponential negative form (decreasing) for the energetic intensity I of the UV radiation:

$$I = I_0 e^{-\mu t} \tag{25}$$

Where: I_0 and μ are the initial value of the radiation previously fixed and depends on the maximum power of the lamp and the decreasing speed of the radiation that

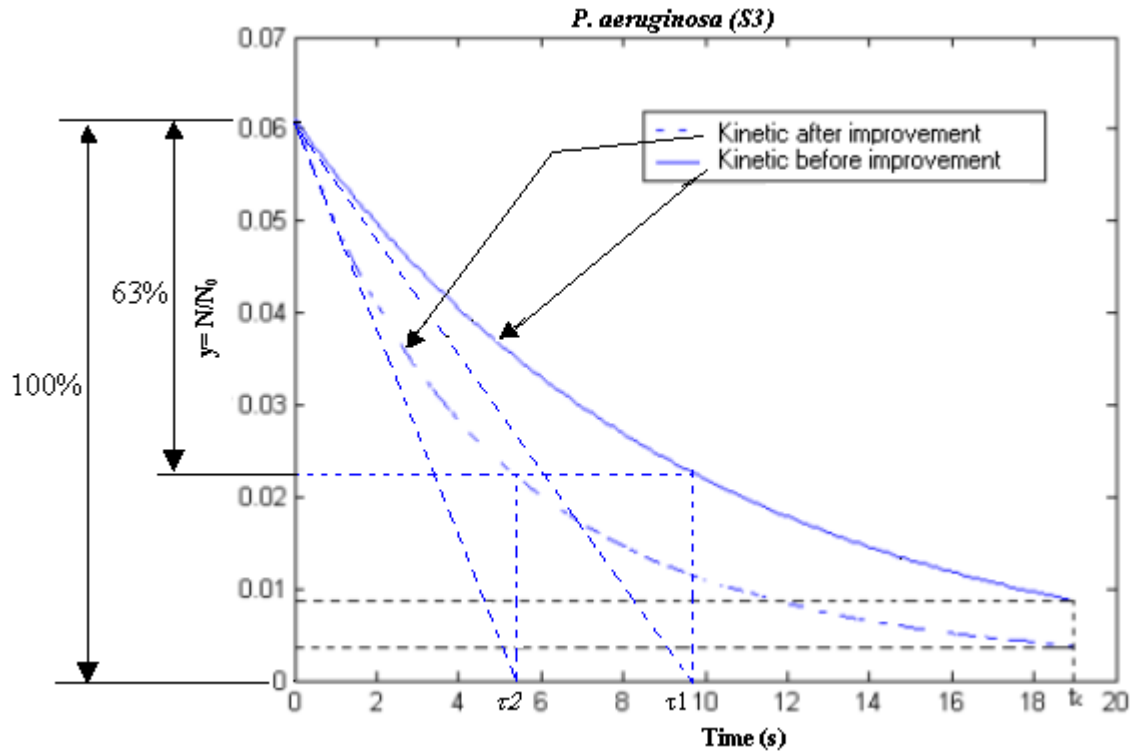

Figure 8. Comparison of two different variations of the energizing radiation on disinfection.

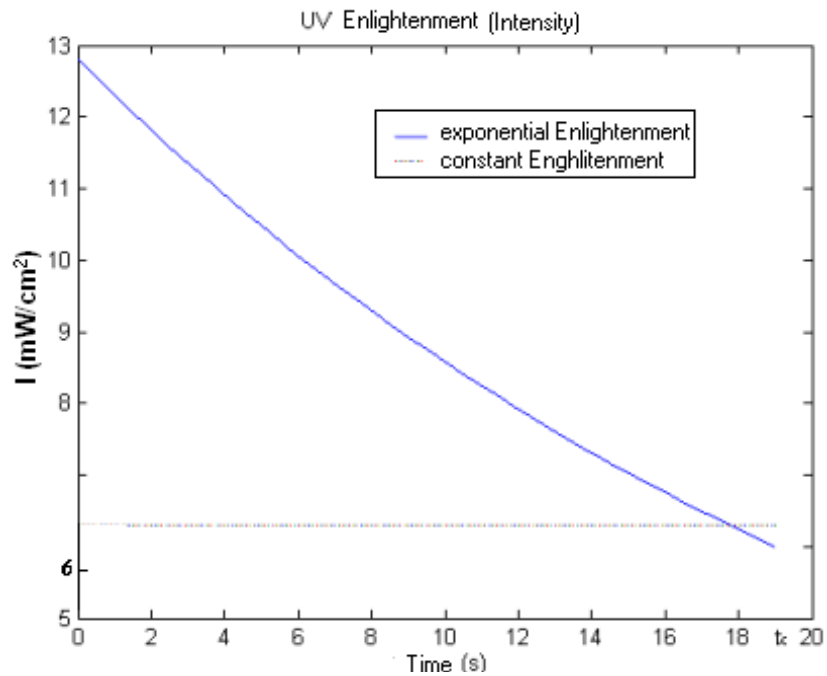

Figure 9. Comparison of variation of the UV intensity depending on the contact time.

can be also previously fixed, respectively. The choice and the dimensioning of these two factors (I_0 and μ) will be done

according to the objectives to achieve.

In this condition of varying radiation (26), the UV flux F_0

emitted by the lamp becomes:

$$F_0 = \frac{I_0}{1.75} \exp(-\mu t) \quad (26)$$

After expressing electric power becomes:

$$P = \frac{I_0}{0.9625} \exp(-\mu t) \quad (27)$$

The model suggested is as follows:

$$\begin{cases} \frac{dy}{dt} = -kIy \\ \frac{dI}{dt} = -\mu I \end{cases} \quad (28)$$

Under these following initial and numeric conditions:

$$\begin{cases} y_0 = A = 0.0611 \\ I_0 = 12.8 \\ k = 0.0163 \\ \mu = 0.04 \end{cases} \quad (29)$$

We supposed in this situation the initial reduction A which is similar to a constant radiation intensity I to guarantee that if the results of disinfection are ameliorated in this precise case. We are sure that they will be improved for an initial radiation I_0 which is more interesting, and then an initial reduction which is more important.

For the strain *P. aeruginosa* ATCC 15442, the results of the model (28) under conditions (29), are given in Figure 8. After improvement of the kinetics of inactivation, the kinetics of disinfection accelerated with a constant time delay of $\tau = 5.35$ s, and the number of bacteria at $t = tc$ became lower.

The simulation of the second equation of the model (29) is represented in Figure 8. The UV dose for a variation over time of the UV intensity (I) constitutes the surface placed between the axis of abscissas, the axis of ordinate and the curve of variation of intensity (I) over time. In this case, the dose for a fixed intensity (I) is 120 mW.s.cm²; on the other hand, in the case where the UV radiation would take a decreasing exponential variation of about 170.5 mW.s.cm², there is an increase of about 42%. The variation of the electric power consumed for the model (27) under conditions (29) is given in Figure 9.

A negative exponential variation of the instantaneous electric power and then a decreasing exponential variation of the average energetic radiation for a perfectly mixed flowing (Figure 10), improved the result of disinfection similar to 49%; this is equivalent to 10⁶ cells of *P.*

aeruginosa at the entry of the reactor, with an improvement of 4900 inactivated cells after the application of the new variation of the radiation; in parallel, the kinetics of disinfection is suitably improved.

Conclusion

The modeling study of UV disinfection kinetics for all studied strains showed that the law of disinfection proposed by the model of Chick-Watson poorly simulated the experimental data. A divergence occurred on the rate of inactivation that was not quite linear. Thus, the original form of this model is not representative of disinfection kinetics.

Modification taking into account the change of disinfection rate during the process did not significantly improved results, indeed. The application of a first order law to the kinetics model of disinfection was therefore possible, if we assumed the existence of two successive steps of different kinetics. The adjustment of the same model but considering an initial reduction describes quite well the kinetics of disinfection for the most studied strains.

The development and improvement of water disinfection remain an urgent goal. From describing the difficulties and the complexities of models of low pressure discharge lamps used in UV water disinfection and from determining an average UV radiation for ideal water flowing, we aimed to freeze a curve of variation throughout time of the average UV intensity. Investigations were done in the optimal conditions of functioning using the most UV resistant bacterial strain as *P. aeruginosa* ATCC 15442 and the UV flux emitted represents 55% of the electric power consumed. Results are satisfactory in considering only the theoretical aspect of UV pathogenic bacteria inactivation.

The complexities of different modeling factors and parameters of UV discharge lamps, the absence of mathematical relations between voltage and fluxes emitted will remain interesting subjects for future research.

Conflict of interest

The authors declare that they have no conflict of interest.

ACKNOWLEDGEMENTS

This study was supported by the European Union (Avicenna Project n° 93AVI054). We express great thanks to all the team of the laboratory of Water Treatment and Recycling, Borj-Cedria Techno-park that contributed from near and far to the success of this work, particularly Mr. Aissaoui and Ms Mabrouk for their help.

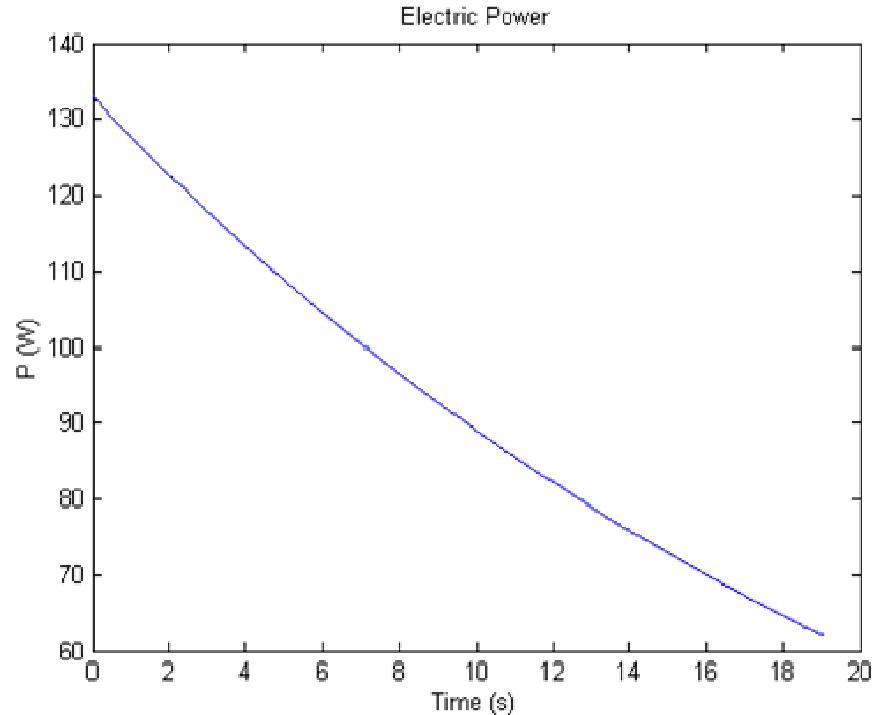

Figure 10. Variation of the electric power consumed.

REFERENCES

- Brahmi M, Hamed BN, Hamdi H, Hassen A (2010). Modeling of secondary treated wastewater disinfection by UV irradiation: Effects of suspended solids content. *J. Environ. Sci.* 22: 1218-1224.
- Brahmi M, Hassen A (2011). Disinfection of Wastewater by UV Irradiation: Influence of Hydrodynamics on the Performance of the Disinfection. *Environ. Eng. Res.* 16:1-10.
- Brahmi M, Hassen A (2012). Ultraviolet Radiation for Microorganism Inactivation in Wastewater. *J. Environ. Prot.* 3:194-202. doi:10.4236/jep.2012.32024.
- Brahmi M, Fourti O, Abdennaceur H (2013). Disinfection of Wastewater by Infiltration-Percolation Coupled to UV Irradiation in an Arid Tunisian Area. *Hydrol. Curr. Res.* 4:1-8. doi:10.4172/2157-7587.1000155.
- Christoph B (2006). Modelling of UV disinfection reactors by means of Computational Fluid Dynamics. Ph.D thesis, in ausgeführt am Atominstytut der "osterreichischen Universit"aten, TU Wien, unter der Anleitung von, Univ. Prof. Dr. Norbert Vana. Im Park 6, 3382 Loosdorf. pp. 3-13.
- Clancy JL, Bukhari Z, Hargy TM, Bolton JR, Dussert BW, Marshal MM (2000). Using UV to inactivate Cryptosporidium. *J. Am. Water Works Assoc.* 92:94-104.
- Costache MC, Damelincourt JJ and Zissis G (2001). Optimizing a source of ultraviolet reactor operating in a water treatment consumption. *J. Phys.* 7:65-66.
- Haas CN (1990). Disinfection, water quality and treatment. In: American Water Works Association, ed. *Water quality and treatment: a handbook of community water supplies*. 4th ed. New York: McGraw-Hill, pp. 879-904.
- Hassen A (1998). Wastewater treatment and study of interactions microorganisms heavy metal - organic matter. Ph.D thesis, In Biological Sciences University of Tunis II, Faculty of Sciences of Tunis. Tunisia. p. 211.
- Hassen A, Jemli M, Nabli M, Boudabous A (1997). Disinfection of wastewater by ultraviolet radiation in a large- scale pilot plant - effect of low dose UV on *Pseudomonas aeruginosa*. *Vector. Environ.* 30: 75-81.
- Hassen A, Mahrouk M, Ouzari H, Cherif M, Boudabous A, Damelincourt JJ (2000). UV disinfection of treated waste water in a large-scale pilot plant and inactivation of selected bacteria in a laboratory UV device. *Bioresour. Technol.* 72:85-93.
- Leahy JG, Rubin AJ, Sprouls OJ (1987). Inactivation of *Giardia muris* cysts by free chlorine. *Appl. Environ. Microb.* 53:154-159.
- Lesavre J, Magoarou P (2004). Methods of Measurement of UV dose disinfection of wastewater. Water Agency Seine-Normandie, Manterre.
- Mamane-Gravetz H, Linden KG (2004). UV disinfection of indigenous aerobic spores: implications for UV reactor validation in unfiltered waters. *Water. Res.* 38:2898-2906.
- Meiting G, Hongying H, Wenjun L (2009). Preliminary investigation on safety of post-UV disinfection of wastewater: bio-stability in laboratory-scale simulated reuse water pipelines. *Int. J. Sci. Technol. Desalt. Water. Purif.* 239:22-28.
- Oparaku NF, Mgbenka BO, Ibeto CN (2011). Wastewater disinfection utilizing ultraviolet light. *J. Environ. Sci. Technol.* 4:73-78.
- Porras D (1998). Numerical simulation of the system "low pressure discharge-power", analysis of the influence of diet on the characteristics of the discharge. Ph.D thesis of the University Paul Sabatier, n° 3079, Toulouse, France. p. 198.
- Qualls RG, Dorfman MH, Johnson JD (1989). Evaluation of the efficiency of ultraviolet disinfection systems. *Water Res.* 23:317-325.
- Roustan M, Stambolieva Z, Duguet JP, Wable O, Mallevalle J (1991). Influence of hydrodynamics on *Giardia* cyst inactivation by ozone. Study by kinetics and by "CT" approach. *Ozone. Sci. Eng.* 13:451-462.
- Sarroukh H, Asselman A, Hassen A, Damelincourt JJ (1999). Determination of direct ultraviolet illumination from the design characteristics of a source Hg-GR. Application in a water treatment reactor. *J. Phys.* 9:117-118.
- Shayeb H, Riabi T, Roustan M, Hassen A (1998). Experimental study and modeling of chlorine disinfection of treated wastewater. *J. Water. Sci.* 4:517-536.
- Sinha RP, Häder DP (2002). UV-induced DNA damage and repair: a

- review. *Photochem. Photobiol. Sci.* 1:225-236.
- Sellami H, Hassen A, Sifaoui MS (2003). Modelling of UV radiation field inside a photoreactor designed for wastewater disinfection- Experimental validation. *J. Quant. Spectrosc. Radiat. Transfer* 78:269-287.
- Trussell RR, Chao JL (1977). Rational design of chlorine contact facilities. *J. Water Pollut. Control Fed.* 49:659-667.
- USEPA (2003b). Voluntary National Guidelines for Management of Onsite and Clustered (Decentralized) Wastewater Treatment Systems. EPA. 832-B-03-001.
- Weinberg HS, Krasner SW, Richardson SW, Thruston AD (2002). The occurrence of disinfection by-products (DBPs) of health concern in drinking water: results of a nationwide DBP occurrence study. EPA Internal Report, EPA/600/R-02/068.
- Zitouni N, Andoulsi R, Sellami A, Mami A, Hassen A (2011). A new Bond Graph Model of a water Disinfection System Based on UV Lamp Feed by Photovoltaic Source: Simulation and Experiment Results. *J. Automat. Sys. Eng.* 5:79-95.
- Zorana N, Soojung L, Ernest R. Blatchley III (2008). Investigation of microbial inactivation efficiency of a UV disinfection system employing an excimer lamp. *Water Res.* 42:4838-4846.