

*Full Length Research Paper*

# Productivity of timber extraction by Urus Mill cable crane from selective spruce forests

Tolga Ozturk

Department of Forest construction and Transportation, Faculty of Forestry, Istanbul University, 34473, Bahcekoky / Istanbul , Turkey. E-mail: [tozturk@istanbul.edu.tr](mailto:tozturk@istanbul.edu.tr). Tel.: +90 212 2261100. Fax: +90 212 2261113.

Accepted 1 August, 2009

**The purpose of this study is to investigate the productivity of the Urus Mill cable crane during yarding of spruce timber from spruce stands in North Eastern Turkey. Cable crane productivity is determined by using the methods of work and time study. The research concludes that some working characteristics of the Urus Mill cable crane such as transportation speed of the carriage (loaded and unloaded), load volume, time consumptions of felling area, fuel consumptions, productivity of the cable crane and transport distance have an absolute impact on the productivity of the cable crane. In this study, for average 210 meters transporting distance, productivity of Urus Mill cable crane was found 10.08 m<sup>3</sup>/hr on two different corridors. The average fuel consumption was 3.5 - 4.0 liters per operating hour of the Urus Mill cable crane. Costs of Urus Mill cable crane are calculated to 4.6 \$/m<sup>3</sup>.**

**Key words:** Urus Mill cable crane, carriage, timber production, time study.

## INTRODUCTION

Turkey has 21.2 million ha of forests, which occupies 27.2% of its total land area. Approximately 75% of the forested area is on steep lands with slopes greater than 40% in Turkey. Therefore, harvesting in mountainous regions has always posed a special difficulty (GDF, 2009; Ozturk and Senturk, 2006). Harvesting and transportation of woods on mountainous areas are extremely difficult, expensive and time consuming operations (Eroglu et al., 2009). The timber harvesting is still one of the most important forestry activities. The productivity of a forest depends on various ecological factors and their positive and negative effects.

The production of wood raw material are formed various stages that continues from the productive place to market center. These work stages depend on each other like rings of a chain. Success and failures in each stage effect the next stage. The transport of forestry products is realized in two stages. The first one is the primary transport stage which involves the haulage of timbers, while the second one is the secondary transport stage involving the main stage of transport of timbers, generally realized by trucks on forest roads (Senturk and Ozturk, 2005). Primary transportation methods are three types in Turkey's forestry, which are human power, animal power and mechanization. Manual ground skidding (man and gravitation) is applied in small forest areas for extraction of small amount of timber and big amount of fuel wood

over short distances. Animal skidding, mainly by horses and oxes, is used for pre-skidding for bunching distance between 20 m and 100 m. Mechanical skidding is carried out by ground based forestry vehicles. Also Gantner, Koller and Urus Cable crane are used for timber extraction on steep terrains (Ozturk and Demir, 2007).

Cable cranes are among the most important means of yarding and transporting timber and they are being increasingly used in the mountainous regions (Zimbalatta and Proto, 2009; Cabbage and Gorse, 1984). Cable extraction systems are fundamentally different from other timber extraction systems. If cable crane are to be used, it is essential that sufficient time should be allotted to permit the necessary advance planning so that the operation can meet its environmental objectives at a reasonable cost (Eroglu et al., 2009; Dykstra and Heinrich, 1996).

The purpose of this research is to give contribution to going knowledge of the productivity of a Urus Mill cable crane in extraction timbers from Turkey mountainous forests. In this study, Urus Mill cable crane was investigated in point of productivity, cost and fuel consumption.

## MATERIALS AND METHODS

### Materials

In Turkey, Urus Mill cable crane have been in use since the end of 1970's. In mountainous parts of Turkey such as study area, this is

the only possible timber extraction system. That is the reason why the Forest General Directorate in Turkey has imported many of the Urus Mill cable crane, carriages and other equipments. Urus Mill cable crane is mounted on a Mercedes T1500 truck. The transportation distance of the cable crane is 600 m. Four workers are employed for operating the cable crane. The time of installation of the cable crane is between 10-16 hours, while the uninstillation time is between 4 and 8 hours depending on terrain conditions. Urus Mill cable crane in felling area is showed Figure 1. The technical features of the Urus Mill cable crane are follows: (i) Base trucks is Mercedes 1500 T; (ii) The weight of cable crane is 8500 kg; (iii) Engine power is 160 HP and diesel engine; (iv) Fuel depot is 180 l; (v) Maksimum cable speed is 3.5 m/s. (vi) Maksimum load weight transporting of cable crane is 2 t; (vii) Diameter/length of main line are 18 mm/600 m; (viii) Diameter/length of drawing line are 10 mm/600 m; (ix) Diameter/length of haulback line are 12 mm/1200 m; (x) Diameter/length of mounting cable are 8 mm/600 m; (xi) Fuel consumption is 30 l/day (Ozturk, 2004).



Figure 1. Urus Mill cable crane in felling area.

### Study area

In order to conduct this research, the first step was to choose the harvesting area. The selected study area is situated in Artvin province (Figure 2) where the forest is managed by Taslıca Forest Office within the Artvin Forest Administration. Taslıca Forest Office manages 11562 ha of forest with the growing stock 3.1 million m<sup>3</sup>. Road density of this region is 15.84 m/ha. The most important commercial tree species are *Picea orientalis* (L.) Link., *Abies nordmanniana* (Stev.) Mattf., *Fagus orientalis* (Lipsky.) and *Pinus sylvestris* (L.).

The study was done inside two forest sub-compartments. The numbers of these sub-compartments are 288 and 289. The study was done in August 2007. The sub-compartments' areas are 42 and 48 ha and the volume of removal are 400 and 450 m<sup>3</sup> respectively. Length of timber assortments ranges from 4 to 6 meters.

### Variables and data collection

In this study, as mentioned in the abstract, we try to measure the impact of the following independent variables to "total cycle time" (total time). In here the total cycle time is chosen as a dependent variable whereas; "outhaul empty", "lateral out", "hookup", "lateral in", "in haul", "unhook" and "lost time" have been selected as independent variables. Beyond that, independent variables of "extraction distance", "lateral bunching distance", "load volume" and "timber quantity" have been chosen as independent variables as well to impact on total cycle time as mentioned in the former sentence.

The definitions of both dependent and independent variables and how to measure them are summarized below:

#### Dependent variable:

**t = total time**, which is measured as time at scale level variable and the measurement unit is minute.

#### Independent variables:

**a = outhaul empty** is started when the operator is ready to move the carriage from the choke setter. Then, this phase ends when the choke setter keeps the hook.

**b = lateral out**, this phase begins at the end of outhaul empty and ends when the choke setter is ready to hook a turn.

**c = hookup**, it begins at the end of lateral out and ends when the choke setter has completed hooking, then the signals to operator by radio phone to begin yarding period.

**d = lateral in**, begins at the end of hookup period. And it ends when the operator is ready to move the carriage to the destination.

**e = in haul**, begins at the end of lateral in and ends when the carriage has reached to the ramp. Then, the hook is unlocked and the log is left to the ground.

**f = unhook** begins at the end of in haul when the carriage passes over to the trip block and ends when the hook is pulled back to the loading point.

**g = lost time** is the time lost when carrying the log.

**Ed = extraction distance** which is described as distance between loading point and destination. The distance is measured by meter and marked at regular intervals and recorded.

**Lbd = lateral bunching distance** is described as a distance between cable crane and the closest log and is measured either by pacing the distance or by ocular estimation of it.

**Lv = load volume** is a variable that represents the volume of all transported logs at the destination. This variable is measured as cubic meters.

All the variables given above are considered as scale variable. Then, theoretically the mathematical equation below is obtained:

$$t = a + b + c + d + e + f + g + Ed + Lbd + Lv$$

In here, I set up the hypothesis below:

$$H_0 = R^2_{y,a,b,c,d,e,f,g,ed,lbd,lv} = 0.0 \text{ (Null hypothesis) versus.}$$

$$H_a = R^2_{y,a,b,c,d,e,f,g,ed,lbd,lv} > 0.0 \text{ (Alternative).}$$

$H_0$  (null hypothesis) means that the proportion of variance in total cycle time (t) that is explained by outhaul empty, lateral out, hookup, lateral in, in haul, unhook, lost time, extraction distance, lateral bunching distance, load volume included in regression model is equal to zero, in the population from which the sample was selected. Null hypothesis also implies that none of the independent variables has statistically significant effect on total cycle time.

Alternative hypothesis means that the proportion of variance in total cycle time that is explained by the set of ten independent variables included in the regression model is greater than zero, in the population from which the sample was selected. Also, it implies that at least one of these independent variables has statistically significant and linear effect on total cycle time.

### Time measurements

The time period between work stages is measured by using chronometer and repetition technique (Aykut, 1986). Study report cards are filled with data for each particular time period. Urus Mill cable crane is investigated in terms of work performance by using time

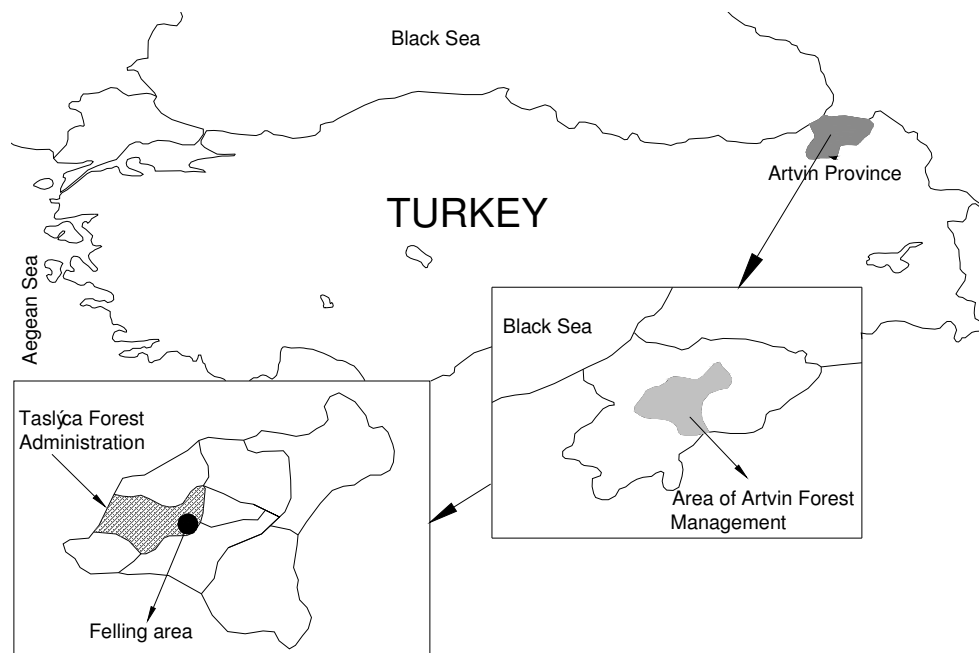

Figure 2. Artvin province and felling area.

and work study methods. The distance of transporting is measured by using a measuring tape. And the slope gradient of the terrain is measured by clinometers and diameter of each piece of timber under bark is measured by compass as well. A detailed time and motion study was conducted using the repetition-timing method to determine the total yarding cycle times, which is the amount of time it takes the carriage to travel from the landing and unhook the payload. Work components was identified and timed to determine the total cycle time (LeDoux and Huyler, 1997).

## RESULTS AND DISCUSSION

### Analysis

SPSS Statistical Software and Excel 2003 were used for carrying out the analysis. A regression model was developed for the statistical analysis. Initially 95% significance level was set to test the null and alternative hypothesis presented above. F-test (variance analysis) was used for testing whether the data verify statistical model or not.  $F\text{-test} = 156.335$  and statistically significant based on 0.05 significance level. Since  $F\text{-test} (156.335)$  is higher than  $F_{0.005, (2.30)}$  we have reject the null hypothesis that none of these independent variables has a statistically significant effect on total cycle time.

Consequently, the data were consistent with the alternative hypothesis that the proportion of variance in total cycle time ( $t$ ), explained by the set of independent variables included in the regression model, was greater than 0.0 in the population from which this sample was selected. It also implied that at least one of these independent variables had statistically significant effect on total cycle time and this relationship was linear.

The regression model is prepared for the study area as follows:

$$t = 0,160 + 1,006 \times b + 0,992 \times g + 1,003 \times a + 0,945 \times d + 0,963 \times c + 1,113 \times f$$

In preparing the model for the study area, if the effects of other variables are hold constant above the dependent variables, the model for felling area, the coefficient of Durbin-Watson, is found as 2,020. Since the coefficient is about to 2 or below, there is no correlation between the independent variables which form the model are completely separate from each other.

The first result that the research reveals is that there is a linear and positive correlation between the set of ten independent variables (outhaul empty, lateral out, hookup, lateral in, in haul, unhook, lost time, extraction distance, lateral bunching distance, load volume) and dependent variable (total cycle time). This implies that when each of the independent variable increases total cycle time increases as well.

When relationship about between each of these independent variables and total cycle time we can find out some sound and clear conclusions.

### Total cycle time ( $t$ ) vs. lateral out ( $b$ )

The unstandardized coefficient is 1.006, which means that the relationships lateral out and total cycle time is positive. When outhaul empty increases one minute total cycle time increases 1.006 minutes, when control all other variables constant. Since beta ( $\beta$ ) is 0.251, the re-

relationship between lateral out and total cycle time is weak, but statistically significant. Beta coefficient means that for each standard deviation increases in the lateral out, total cycle time increases 0.251 units, when we control all other independent variables constant in the model. Since the coefficient is statistically significant, the relationship between total cycle time and lateral out is linear.

#### **Total cycle time (t) vs. lost time (g)**

The unstandardized coefficient is 0.992, which means that the relationship lost time and total cycle time is positive. When lost time increases one minute total cycle time increases 0.992 minutes, when control all other variables constant. Since beta ( $\beta$ ) is 0.310, the relationship between lost time and total cycle time is moderate, but statistically significant. Beta coefficient means that for each standard deviation increases in the lost time, total cycle time increases 0.310 units, when we control all other independent variables constant in the model. Since the coefficient is statistically significant, the relationship between total cycle time and lost time is linear.

#### **Total cycle time (t) vs. outhaul empty (a)**

The unstandardized coefficient is 1.003, which means that the relationship outhaul empty and total cycle time is positive. When outhaul empty increases one minute total cycle time increases 1.003 minutes, when control all other variables constant. Since beta ( $\beta$ ) is 0.481 the relationship between outhaul empty and total cycle time is moderate, but statistically significant. Beta coefficient means that for each standard deviation increases in the outhaul empty, total cycle time increases 0.481 units, when we control all other independent variables constant in the model. Since the coefficient is statistically significant, the relationship between total cycle time and outhaul empty is linear.

#### **Total cycle time (t) vs. lateral in (d)**

The unstandardized coefficient is 0.945, which means that the relationship lateral in and total cycle time is positive. When lateral in increases one minute total cycle time increases 0.945 minutes, when control all other variables constant. Since beta ( $\beta$ ) is 0.280, the relationship between lateral in and total cycle time is weak, but statistically significant. Beta coefficient means that for each standard deviation increases in the lateral in, total cycle time increases 0.280 units, when we control all other independent variables constant in the model. Since the coefficient is statistically significant, the relationship between total cycle time and lateral in is linear.

#### **Total cycle time (t) vs. hookup (c)**

The unstandardized coefficient is 0.963, which means that the relationship hookup and total cycle time is positive. When hookup increases one minute total cycle time increases 0.963 minutes, when control all other variables constant. Since beta ( $\beta$ ) is 0.260, the relationship between hookup and total cycle time is weak, but statistically significant. Beta coefficient means that for each standard deviation increases in the hookup, total cycle time increases 0.260 units, when we control all other independent variables constant in the model. Since the coefficient is statistically significant, the relationship between total cycle time and hookup is linear.

#### **Total cycle time (t) vs. unhook (f)**

The unstandardized coefficient is 1,113, which means that the relationship unhook and total cycle time is positive. When unhook increases one minute total cycle time increases 1,113 minutes, when control all other variables constant. Since beta ( $\beta$ ) is 0.255, the relationship between unhook and total cycle time is weak, but statistically significant. Beta coefficient means that for each standard deviation increases in unhook total cycle time increases 0.255 units, when we control all other independent variables constant in the model. Since the coefficient is statistically significant, the relationship between total cycle time and unhook is linear.

The relationship between transport distance and time consumption are showed Figure 3. The relationship between transport distance and time consumption is linear. More and more transport distance, time consumption is increasing in felling area.

#### **Productivity**

The paper shows the results of research of transporting spruce timber from spruce forests of Turkey by the Urus MIII cable crane. Installation line length of cable crane 600 m and worked four workers at this cable crane. Lateral bunching distance was between 5 - 20 m. Two corridors in felling area are opened for cable crane. Along trace of cable crane is used two intermediate supports for both corridors. The height of intermediate supports was between 10 - 12 m. The timber transport is done uphill. Timber is stacked in unloading area. Then, timber is loaded on trucks. Loading works are done with a loader. Secondary transport is endured to 25 - 35 km by trucks.

Cable crane performance was being observed at felling area for 15 working days. During that time 850 m<sup>3</sup> of timber was extracted in 75 recorded cycles. Timber transportation is made from five different distance and time measurements are made at these distances. Urus MIII Cable crane's time of transporting for one cycle from distance 190, 200, 210, 220 and 230 m arranges the average 7.36, 7.27, 8.14, 10.03 and 8.17 min in the felling

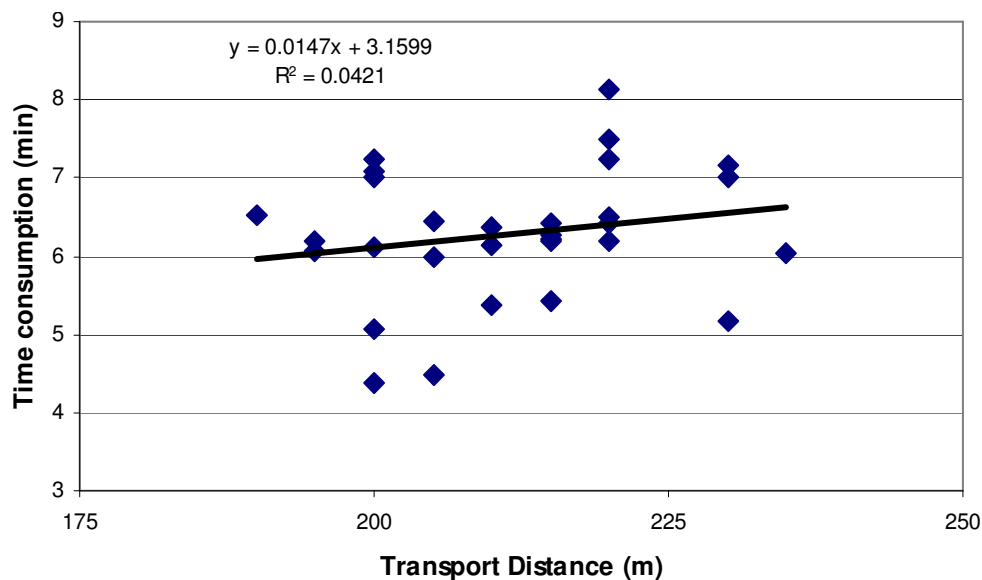

Figure 3. Relationship between transport distance and time consumption.

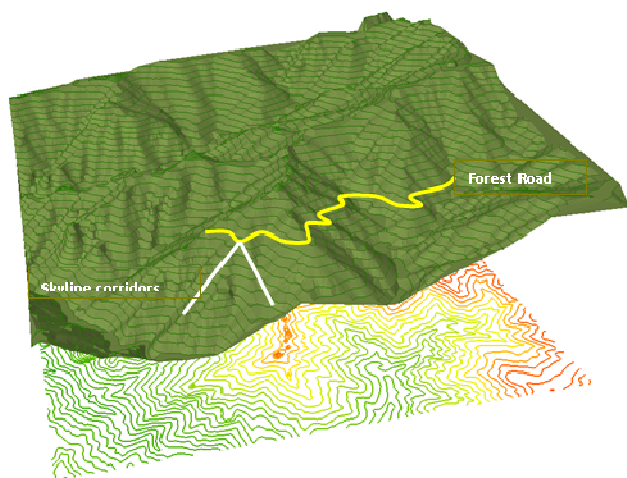

Figure 4. Image of felling area and corridors of cable crane.

felling area. The average time of transporting is found as 8.20 min, for one cycle transporting the quantity of load volume is average 1.400 m<sup>3</sup> and average pieces of load is 2. The image of felling area and corridors of cable crane is shown in Figure 4.

The widths of corridors are changed between 2 and 3 m. The environmental damages were not shown on the sides of corridors and soil disturbance were not shown along the corridors. Results of time measurements are indicated in Table 1. The average percent of working components of Urus MIII cable crane is illustrated in Figure 5.

Operation phases most effective on total time and productivity was determined as outhaul empty (a), lateral be used between cable crane operator and choker setters

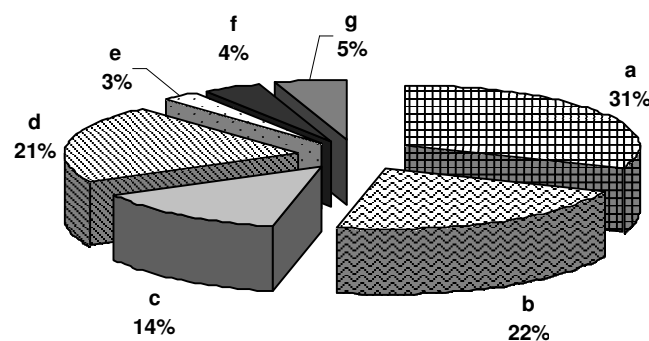

Figure 5. Average percentages of Urus MIII cable crane working components.

for communication, and much more choker should out (b), and lateral in (d). The felling sequence should be chosen with consideration for efficiency, wireless should be used for loading. The lost time was not founded effective inside working components. Two chokers were worked in this study and the number of chokers were found enough. Because, the average hookup and unhook times were found low (average 1.00 and 0.28 min).

The average productivity at felling area is 10.080 m<sup>3</sup>/h. The productivity inside a day of cable crane was 80.64 m<sup>3</sup>/day. The average lost time is 0.35 min/cycle. Lost times inside working area are taken form at different points. These points are unloading area and defect of carriage during transporting on main line. Daily fuel consumption was measured by volume method. The average fuel consumption per operating hour ranged between 3.5 and 4.0 l/h. The time consumption of working components is shown in Figure 6. When moving on a main line, average speed of a loaded carriage (downhill) is

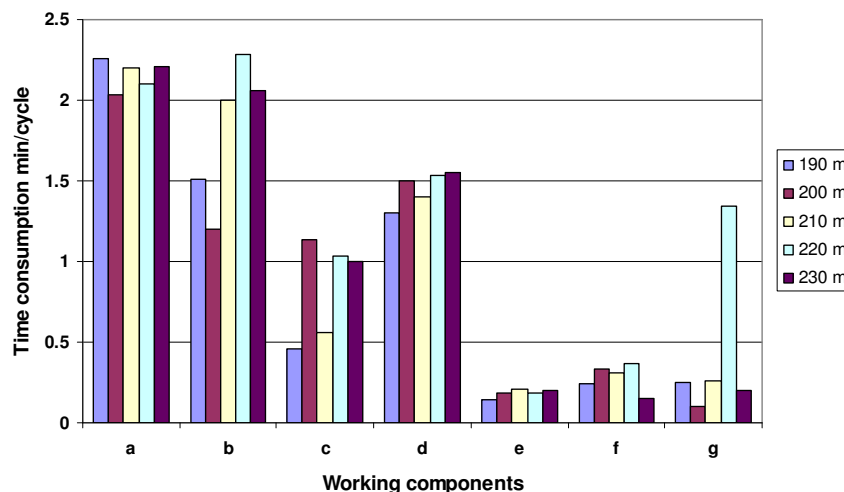

Figure 6. Time consumptions of working component.

Table 1. Time measurements of cable crane.

Yarding distance (m)	Lateral bunching (m)	Load volume (m <sup>3</sup> )	Load amount (Number)	Working components							
				a	b	c	d	e	f	g	h
190	9	1.045	2	2.26	1.51	0.46	1.30	0.14	0.24	0.25	7.36
200	10	1.345	2	2.03	1.20	1.13	1.50	0.18	0.33	0.10	7.27
210	10	1.260	2	2.20	2.00	0.56	1.40	0.21	0.31	0.26	8.14
220	13	1.275	2	2.10	2.28	1.03	1.53	0.18	0.37	1.34	10.03
230	17	2.083	3	2.21	2.06	1.00	1.55	0.20	0.15	0.20	8.17
Average	12	1.400	2	2.16	1.57	1.00	1.46	0.18	0.28	0.35	8.20

1.96 m/s and average speed of unloaded carriage (uphill) is 1.65 m/s (10% higher). The cost of Urus MIII cable crane was found as 4.60 \$/m<sup>3</sup> in this felling area. This cost was calculated according to transporting distance, lateral distance and number of workers. The manual skidding distance of timber on lateral distance is very important in terms of cost calculations.

## Conclusions

In this study, productivity of Urus MIII was found as 10.080 m<sup>3</sup>/h for transporting distance (for average 210 m). In a similar study conducted by Aykut et al. (1997) in Artvin Meydancik region, transporting distance for 240 meters, productivity of Urus MIII was found 8.60 m<sup>3</sup>/h. Another studies, Caglar (2002), transporting distance for 600 m, productivity of Urus MIII was found as 3.80 m<sup>3</sup>/h, Ozturk (2004), transporting distance for 350 m, productivity of Urus MIII was found as 12.90 m<sup>3</sup>/h. Thus, the productivity value in this study area is not very different from productivity values of other studies.

In this study, the average cost of Urus MIII skyline was calculated as 4.60 \$/m<sup>3</sup> (for average 210 m). A study

conducted in Artvin region (Ozturk, 1997) reported that cost of Urus MIII cable crane was found 13.14 \$/m<sup>3</sup> (for average 450 m). The cost value is found lower. Because, lateral skidding distance of timber in this study area is shorter according to another study area.

In the light of the results of this study, the following recommendations should be taken into consideration in order to ensure the performance of timber haulage operations is a more effective and productive way.

Urus MIII cable crane is a very important machine for extraction of timber. This cable crane is speed and productive. The mounting and dismounting of this cable crane is easy and economical.

The products extraction with cable crane has high quality and the lost value stays minimal. Environment, forest soil and other plants in study area is not damages.

In the areas where the log transportation is performed by cable crane, after determining its route and setting carriage line, the logs harvested and scattered in the vicinity of the line are skidding toward the cable crane by human force. Thus, lateral out distance is too shortened and the time period will be decreased to some extend. Therefore, the hourly performance of the cable crane will be increased significantly. On the other hand, when

hiring more workers than as usual the lateral out phase and tie phase will be increased.

On the other hand it is required to regard regular maintenance work based on technical prospectus. Therefore the fuel consumption and the repairing needs are decreased as well.

For the operation of a cable system in the forest land, there must be an adequate quantity of wood raw materials in the haulage area. In the area where timber haulage is to be carried out, the forest cable systems should be brought to the area and installed after production operations are completed, and then the haulage operation should be performed. The mounting of skylines should not be made before completion of production operations.

## REFERENCES

- Aykut T (1986). The used cable systems at transporting of forest. I.U. Review of the Faculty of Forestry 36 (B1): 53-71.
- Aykut T, Acar HH, Senturk N (1997). An investigation on the comparison of Koller K300, Urus Mill and Gantner skylines used for extraction from compartment in Artvin region. I.U. Review of the Faculty of Forestry 47(A2): 30-58.
- Caglar S (2002). Investigation of working productivity of extraction by cable cranes in forests of Artvin. K.T.U. Master Thesis, Trabzon.
- Cabbage FW, Gorse AH (1984). Mountain logging with the Bitterroot mini yarder. Proceedings of the mountain logging symposium, Morgantown, West Virginia University, USA.
- Eroglu H, Ozkaya MS, Acar HH, Karaman A, Yolasiğmaz HA (2009). An investigation on roundwood extraction of *Fagus orientalis* lipsky, *Abies nordmanniana* (Stew.) Spach. and *Picea orientalis* (L.) Link. by Urus Mill forest skyline on snow. Afr. J. Biotechnol. 8(6): 1082-1089.
- Dykstra DP, Heinrich R (1996). FAO model code of forest harvesting practice. Rome pp.84-85.
- GDF (2009). Genral Forest Directorate internet page, www.ogm.gov.tr
- Ledoux CB, Huylar NK (1997). Cycle time equation for the Koller K300 cable yarder operating on steep slopes in the Northeast, USDA Forest Service, Research Paper NE-705, USA.
- Ozturk T (1997). The Possibilities of using skyline cranes in Artvin forests in Turkey. I.U. Review of the Faculty of Forestry, University of Istanbul 47 (A2): 147-175.
- Ozturk T (2004). The research on transporting forest products with varied forest cable crane in mountainous forest zone of Turkey. I.U. Review of the Faculty of Forestry 54(A1): 165-187.
- Ozturk T, Senturk N (2006). Extraction of spruce timber by Gantner cable crane from selective forests of Artvin region. Croatian J. For. Eng. 27(1): 59-66.
- Ozturk T, Demir M (2007). Transporting of spruce timbers by Urus Mill cable system from selective forests of Artvin region. Building Environ. 42: 1278-1282.
- Senturk N, Ozturk T (2005). Evaluation of Timber Extraction Machines in Turkey. Am. J. Environ. Sci. 1(1): 81-85.
- Zimbalatta G, Proto AR (2009). Cable logging opportunities for firewood in Calabrian forests. Biosyst. Eng. 102: 63-68.