

Full Length Research Paper

A device for thermal conductivity measurement in a developing economy

I. O. Owate*, O. E. Abumere and G.O. Awwiri

Department of Physics, University of Port Harcourt, Choba, Rivers State, Nigeria.

Accepted 5 March, 2007

Thermal conductivities of copper, aluminium and brass materials have been determined using a system designed, constructed and tested. The system is a modified form of Smith's thermal conductivity apparatus which has been widely applied in normal laboratory (1-3). It consists of a heating chamber (made by sandwiching heating coil within ceramic thermal insulators), sample holder region and the cold end area. The thermal conductivities of copper, aluminium, and brass were measured using the system and the results obtained were compared statistically with other standards. It was observed that the measured thermal conductivity values were 397.4 ± 2.2 , 238.0 ± 1.3 and $110.2 \pm 1.2 \text{ Wm}^{-1} \text{ K}^{-1}$ for copper, aluminium and brass respectively. These results compared relatively well with other standard values. Such values are in order 396, 236 and $109 \text{ Wm}^{-1} \text{ K}^{-1}$. The results obtained certified the aim of the work which was to fabricate a thermal conductivity measurement system suitable for data collection and experimental experience in a developing economic environment. Consequently, the analysis shows that the device can be reproduced for thermal conductivity measurements in a developing laboratory experimental environment.

Key words: Thermal conductivity, aluminum, copper, brass and design.

INTRODUCTION

Thermal conductivity is defined as the quantity of heat transmitted through a unit thickness of materials in a direction as a result of temperature difference under steady state boundary condition. This implies that heat conduction occurs when a body is exposed to temperature gradient and becomes serious when different parts of a body experience differential temperature ratings. The consequence of that is the initiation of heat flow from the higher temperature region to the lower region. If the material (metal) is uniform (in terms of composition and dimensions) then the temperature along a chosen length decreases uniformly with distance from the relatively hot region to the cold point (Cairns et al). Also, Callender (1987) stated that when the temperature at any particular point of a body remains constant with time, a condition of steady state heat flow is assumed to have established. Advances in electrical and electronic products have resulted in the development of high power component linkage through high power circuitry conduction paths³⁻⁶. Both processes require thermal and electrical insulation from

heat dissipation and thermal conduction as observed by Kaufman⁵. For good conductors of heat, Searle's bar method can be used (Callister, 2003), whereas for poor conductors of heat, Lees' disc method can be used (Halliday et al., 1997). VELA is an old data logging machine but an alternative traditional method of using real thermometers has been described by other workers (5-852-6 AFR 88-19, Volume 6, Army Corp of Engineers publication). A brief review of relatively new class of dynamic methods that has been widely used for measuring thermal conductivity and specific heat within a single measurement is available (Srivastava, 1990). A thermal conductance tester, one of the instruments of gemology, determines if gems are genuine diamonds using diamond's uniquely high thermal conductivity. Consequently, thermal conductivity of electrical materials is an important parameter that should be easily determined by any practicing laboratory. Therefore there is need to develop a suitable reproducible method for the estimation of thermal conductivity of metallic materials in a developing economy such as that of Nigeria. In metals, thermal conductivity approximately tracks electrical conductivity, as freely moving valence electrons transfer not only electric current but also heat energy (Gustafson, 1991; Karawacki

*Corresponding author. E-mail: owateio@yahoo.com.

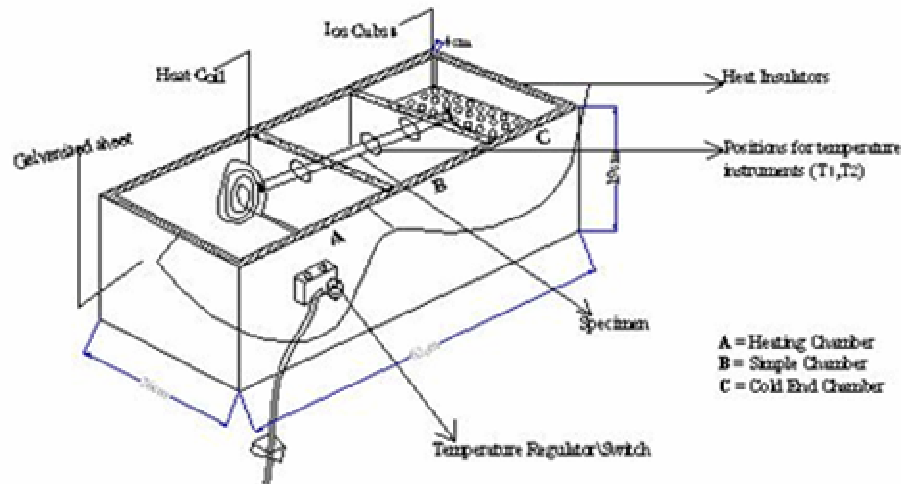

Figure 1. Schematic design of the system.

and Gustavson, 1994; Ishioma, 2005). However, the general correlation between electrical and thermal conductance is broken in other materials such as semiconductors, due to the relative importance of phonon carriers for heat in non-metals and other related materials.

Thermal conductivity depends on many properties of a material, notably its microstructure and temperature. For instance, pure crystalline substances exhibit highly variable thermal conductivities along different crystal axes, due to differences in phonon coupling along a given crystal dimension (Meadean 1990; <http://www.engineeringtoolbox.com/thermal-conductivity-429.html> 2/22/2007; Crispin and Nichas, 1989). Sapphire is a notable example of variable thermal conductivity based on orientation and temperature, for which the CRC Handbook reports a thermal conductivity of 2.6 W/m.K perpendiculars to the c-axis at 373 K, but 6000 W/m.K at 36 degrees from the c-axis and 35k. It has been reported (Srivastava 1990¹⁹) that the thermal conductivities of brass, aluminum, copper and their alloys range from 24 to about 412 Wm⁻¹ K⁻¹ with copper having the highest value. However, the preferred metal alongside its substrate for both electrical and electronic applications is copper. Some researchers¹⁰ have reached advanced stages to produce copper-aluminum alloys as possible alternative material instead of pure copper system. The specific areas where advances have been made include assessment of the surface characteristics, coating properties and the possibility of screen-printing of the composite copper-aluminum system. The present work will concentrate on the design, construction and testing of a model for a quick estimation of thermal conductivity of metals and their alloys. The principle applied in this work is derived from Smith's apparatus (Figure 2) with some modifications, Crispin and Nicholas, (1989). Scientists define thermal conductivity, K as the intensive property of a material that shows the ability to conduct heat. Generally, the quantity of heat,

Q transferred in time t, through a thickness L, in a given direction normal to a surface Area A, due to temperature difference ΔT under steady state condition is given by

$$K = \frac{QL}{EADT} \quad \text{----- (1)}$$

MATERIALS AND METHOD

The procedures employed include the design stage, construction and testing (estimation of thermal conductivities of copper, aluminum and brass). The materials used were galvanized stainless sheets, thermal insulators (alumina-ceramics), heating system, copper-constantan thermocouple, ice blocks and mercury in glass thermometer (for calibration).

Design Stage

The system consists of three parts namely; the heating chamber sample holder chamber and the Cold-End chamber (Figure 1).

The heating chamber

The heating chamber has an embedded heating coil with an electrically power supply system. The chamber was generally lagged with thermal insulators for the purpose of controlling and conserving much of the heat generated by the heater. Part of the test specimen was allowed to extend into this section in order to create a temperature gradient along the test sample. This allows one to measure the temperature difference along the samples. The specimen chamber was designed to hold either the cylindrical or rectangular specimen. Four circular openings (of known length with 5.5 mm spacing) were drilled through the specimen surface for the insertion of thermocouples during temperature measurements. This chamber was equally insulated from much heat losses by adapting lagging process. The cold-end section consists of a chamber for ice-block storage and provision for water drain-out. The other end of the specimen also spills into this section thereby creating the thermal gradient required for heat flow.

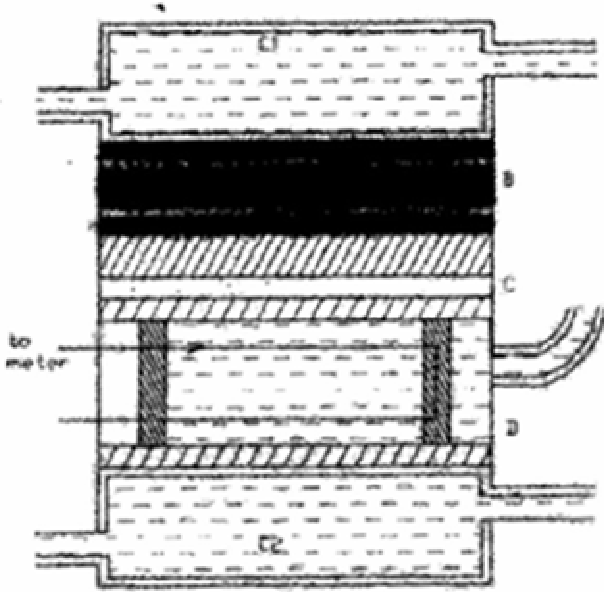

Figure 2. Illustration of Smith's apparatus.

Theory

The description of the design implies that the expression for thermal conductivity is given by K as derived by Meadan.

$$K = \frac{QL}{A(T_2 - T_1)} \quad \text{----- (2)}$$

$$\text{And } Q = VI \quad \text{----- (3)}$$

- Q = Quantity of electrical energy delivered per second
- V = Voltage per second
- I = Current delivered
- L = Distance between T₁ and T₂.
- T₂ = Temperature of hot point
- T₁ = Temperature of cold point
- A = Cross sectional area of specimen.

The thermal conductivity K is calculated from the expression given above where, the solid specimens used were cylindrical in shape and the cross-sectional area A, employed in equation (2) is given by

$$A = 22/7[d^2/4] = 22d^2 / 28 \quad 4$$

Where d = diameter of the cylinder.

Consequently, the current (power produced) was regulated by the electrical system of the heater. This implies that by regulating the allowed current through the resistance coil of the heater, the power of the heating wire rises accordingly. For example at a current of 6.25A and a voltage source supplied of 240 V, the heat generated Q is given by

$$Q = 240 \times 6.25 \quad \text{----- (5)}$$

$$= 1500 \text{ W}$$

This calculation follows for other current settings, which were measured.

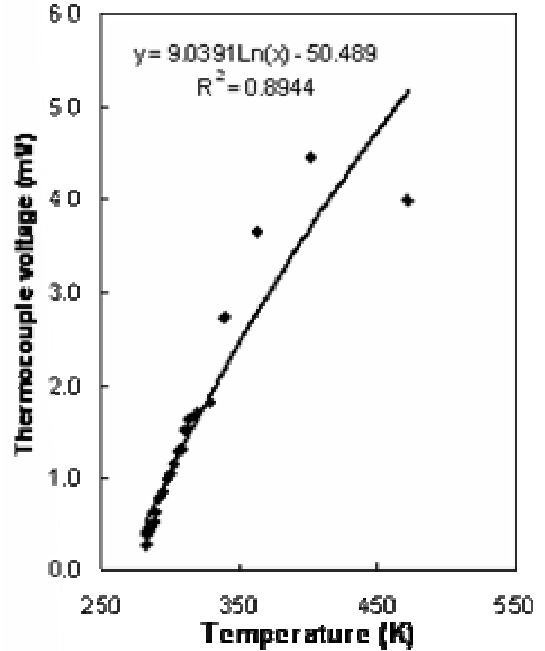

Figure 3. Calibration curve for temperature (K) for the modified system.

Testing and calibration of the measurement system

A two hundred and forty (240) volt ac power supply unit, two digital thermocouple and mercury-in-glass thermometer (20 – 350°C) are the apparatus that were applied in the following measurements. Firstly, the system was connected to an electrical power supply unit of 240 volts and allowed to be thermally stable. Thereafter, thermocouples for use were calibrated using mercury-in-glass thermometer. The electrical power control knob was adjusted to a pre-determined power output and then a piece of specimen of 5.5 cm length and 5.5 x 10⁻² mm diameter which was machined to fine-finish and washed in de-ionized water, and dried in open air was used for the measurement. The specimen was individually placed in the sample holder and care was taken to insure all components within the system were thermally lagged to prevent much heat losses. Measurements were obtained when the temperature was fairly stable and, the measured temperature gradient was applied to equation 1 in obtaining the values of the thermal conductivities for the samples. Similarly, the thermal conductivities for each sample were determined at increasing power supply (temperature). This was achieved by increasing the electrical power supply through the adjustable control knob.

RESULTS AND DISCUSSION

The temperature calibration curves in Kelvins for the thermocouple applied are shown in Figure 3 [Kelvin] whereas Figure 4 is for the °C. It was noticed that the °C scale had a percentage fit of 98.7% whereas a 96.44% was obtained for K scale. Consequently, the temperature gradient values applied for calculating the thermal conductivities were extrapolated from Figure 4.

Table 1. Measured Thermal Conductivities ($\text{Wm}^{-1}\text{K}^{-1}$) for Copper, Aluminum and Brass at 240 Volts

Ser/No	Copper	Aluminum	Brass
1	390	236	108
2	398	241	110
3	401	234	109
4	390	251	114
5	397	228	111
6	396	243	120
7	398	236	104
8	410	240	102
9	403	231	105
10	391	240	119
Mean	397.4 ± 2	243 ± 20.67	110 ± 2
STD	390 ± 2.0	236.1 ± 1	109 ± 1 (ref 20)
% error	1.89	2.97	1

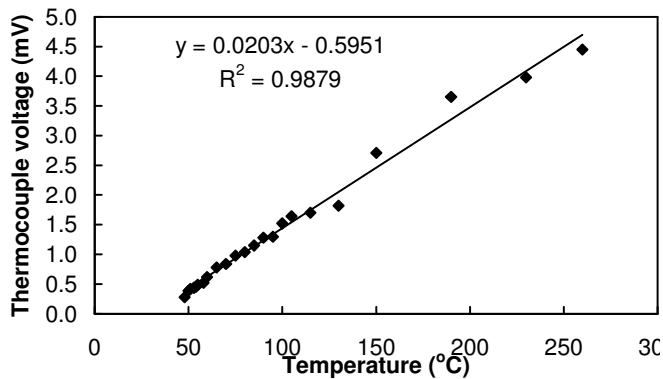
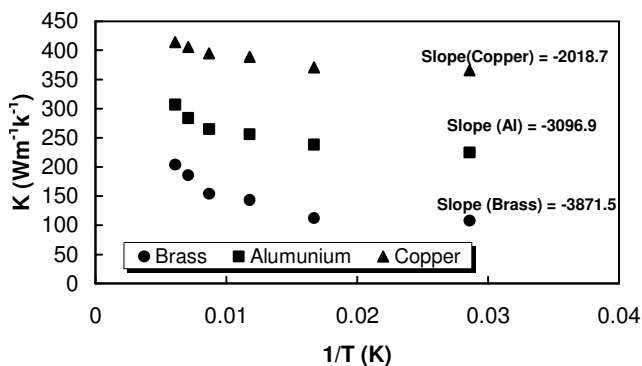
**Figure 4.** Calibration curve for temperature in $^{\circ}\text{C}$.**Figure 5.** Variation of thermal conductivity with temperature.

The measured thermal conductivities for copper, aluminium and brass are presented in Table 1 with their mean values and percentage errors. It was observed that brass had the least percentage error of 1.0% whereas aluminium

recorded the highest (2.97%). Figure 5 is an Arrhenius plot of the variation of thermal conductivity against the reciprocal of temperature in Kelvin (K). The slopes for the different materials were derived from equation 1 and expressed as

$$\text{Slope} = \theta = \frac{QL}{A} \quad 4$$

It was then possible to estimate the quantity of heat Q used for excitation. The calculated values for copper, brass and aluminium were 88.59, 70.87 and 46.19 J respectively. This implies that aluminium had smaller quantity of heat for excitation than for heat conduction process than brass and copper. This simple but brief experiment demonstrates that the measurement of thermal conductivities of some metals and alloys can be achieved to great extent of accuracy by employing the simple and reproducible design presented.

Conclusion

The designed system for the measurement of thermal conductivity of metals was applied to copper, aluminium and brass as the test specimen materials. Values of thermal conductivities obtained compared favourably with that of other workers. In addition, reasonable values were obtained despite some heat sinks process. The variations of percentage error were between 1.0 to 2.97% which was in good comparison with values obtained by other researchers. Lastly, the values of thermal conductivities obtained were relatively within Standard values.

REFERENCES

- Cairns JA, Segel DL, Woodhead JL (1984) Mater. Res. 32: 61.
- Lee CC, Glass H (1985). Appl. Phys. Lett. 47(7): 651.
- Nelson RL, Ramsay JDF, Woodhead JL, Cairns JA (1991). Thin Solid Films.

- Kaufman JG (2000). Introduction to Aluminum Alloys and Other Metals. ASM Publications, New York.
- Zemansky MW, Dittman RH (1993). Fundamental Concept of Heat Flow, 6th Ed. McGraw Hill, London.
- Gee MG (1980). Electrical Properties of useful Conducting Materials. Heinemann, London.
- Grimval G (1986). Thermophysical Properties of Materials, Student Edition, Wohlforth, India.
- Dewitt DD (1990). Fundamentals of Heat and Mass Transfer 3rd ed. McGraw Hill, New York.
- Blanpied WA (1983). Thermal Conductivities of Metals and Alloys of Low Temperature. John Wiley and Sons Inc. New York.
- Callender JP (1987). Methods of Measuring Thermal Conductivity of Materials. McGraw Hill, New York.
- Callister, William (2003). "Appendix B" Materials Science and Engineering. An introduction. John Wiley & Sons, INC 757. ISBN 0-471-22471-5.
- Halliday David, Resnick, Robert; Walker, Jearl (1997) Fundamentals of Physics (5th ed.) John Wiley and Sons, INC. NY. ISBN 0-471-10558-9. TM 5-852-6 AFR 88-19, Volume 6 (Army Corp of Engineers publication). Srivastava GP (1990). The Physics of Phonons" Adam Hilger, 10P publishing Ltd, Bristol.
- Gustafson SE (1991). Review of Scientific Instruments. 6: 42.
- Karawacki E, Gustavson M (1994). Hot Disc Sensors, Rev. Sci. Instrum. 8: 83.
- Ishioma OL (2005). BSc (Hons.) Thesis Dept of Physics, University of Port Harcourt, Nigeria.
- Meadan CT (1990). Thermal Conductivity of materials Southainpto Technical College Press, Southanpton, UK. pp. 15-16.
<http://www.engineeringtoolbox.com/thermal-conductivity429.html>
2/22/2007
- Crispin RM, Nichas dMG (1989), International Copper Research Association (INCRA) UK.