

*Full Length Research Paper*

# Investigation of the impact of applying TOC in MRP using a case study

Kamaladin Rahmani<sup>1</sup>, Abolfazl Fereydooni<sup>2</sup>, Mahmood Behravesh<sup>3</sup> and Masoud Behravesh<sup>4\*</sup>

<sup>1</sup>Department of Economics and Management, Islamic Azad University -Tabriz Branch, Iran.

<sup>2</sup>Islamic Azad University -Tabriz Branch, Iran.

<sup>3</sup>Department of Industrial Engineering, Sharif University of Technology, Iran.

<sup>4</sup>Department of Economics and Administrative Sciences, Allameh Mohadeth Noori Institute of Higher Education, Iran.

Accepted 2 June, 2010

**In this research, the impact of applying TOC in MRP systems was studied using a case study. First the theories of TOC and MRP and their integration histories were reviewed. The research methodology was devised using library and field studies. The proposed method was applied to Tabriz Diecast Aluminum Casing and Bending Company. The company's organizational documents were used in studying the impact on company operations. The collected documents and information were thoroughly evaluated and analyzed to obtain the final results of using TOC in MRP production systems as presented in this paper. In today's economy, cost reduction and increased production output and quality are regarded as top priorities for survival and competition as they can guarantee the success of a company in the long run.**

**Key words:** Constraint, theory of constraints, manufacturing resource planning OR, manufacturing resource planning (MRP), optimized production techniques (OPT).

## INTRODUCTION

Today, companies compete for more profits by improving quality and production time. To survive in this competitive environment, companies should offer high quality products and services while achieving a faster stock turnover. During the recent decades, production companies have paid more attention to planning, manufacturing, and production of control systems [MPCS]. Three fundamental systems that are generally considered are:

1. Raw material planning
2. Timely production
3. Theory of constraints

Various papers published in the 1980's have tried to find out which of the three is more superior but there is now a consensus that the three fundamental systems are complementary and their successful integration would result in more efficient production systems.

Since the MRP systems were proposed before TOC, implementation of the new system has been typically accompanied by an existing system of MRP. The question is whether MRP and TOC can coexist. By reviewing the existing literature, it is understood that the behavior of an MRP system can be made similar to TOC owing to its flexibility.

## OBJECTIVES AND RESEARCH QUESTION

The objective of this research was to improve the production philosophy of TOC by narrowing the gap between the theory and operational techniques required for the manufacturing environments. It was also intended to overcome the greatest challenges of production industries, which are bottleneck identification and optimum production planning. Addressing these challenges can increase output and decrease operational costs, waste, and delivery times. The fundamental research question can be expressed as follows: Does embedding the TOC process have any impact on MRP?

---

\*Corresponding author. E-mail: behrawesh@gmail.com.

## THEORETICAL BASIS AND LITERATURE REVIEW

MRP is a computerized information system designed for illustration and planning of items with dependent demand. In other words, MRP works in a backward fashion and computes the required amount of time and quantity of parts, accessories, and raw materials with respect to BOM or Bill of Materials and lead times. Thus, MRP provides answers to the following questions:

- What items are required?
- How many are required?
- When are they required?

MRP can be viewed as a priority planning system to determine production needs. However, it does not recognize all the constraints such as production capacity. Rather than dealing with shortage planning, MRP only identifies the shortage and leaves the planning task to the operator. As such, MRP determines the steps that should be taken to produce the end item as opposed to determining the steps that could be taken. (Miltenburg, 2007: 1157).

MRP as a planning system is used to deliver the right item within the right time frame in accordance with the order placed or forecast. This however does not cover the requirements of manufacturing and production environments in this day and age. The fundamental weakness of existing systems is the lack of limited planning logic and priority for detailed planning over capacity planning. This causes numerous inventory loading iterations in order to reduce excess inventory.

In reality, the MRP process is a Master Production Schedule (MPS) broken down to forecast Bill of Materials (BOM) and produce master schedules. The amounts of materials needed are calculated by subtracting the current inventory from the ordered materials. The calculated quantities using the burst method on the product tree indicate the gross demand. In this process, the net demand is determined by subtracting the present and ordered inventory of stocks from the gross demand. If necessary, the precautionary reserves are also added to the calculations (Swann, 1986:33).

The theory of constraints is a completed form of a production planning method entitled "Optimum Production Technology" or OPT. This method concentrates on the production bottlenecks to activate production line equipment in coordination with bottlenecks, thereby minimizing Work-In-process (WIP) or in-process inventory.

According to TOC, the constraints of a system are not many but each system has at least one constraint that prevents it from achieving more of its goal. Based on this theory, the system performance should be coordinated with the performance of its environment so that the WIP is minimized. (Goldratt, 1990:356). The planning horizon in both MRP and TOC systems is a function of input information. Both systems enable overall and coordinated

weekly and monthly planning and even daily planning is feasible in some MRP systems. However, TOC is more accurate in that the planning interval can be reduced to hours or even minutes.

MRP works on the basis of having unlimited amount of resources. Planning in the system is based on standard information and its latency is constantly calculated for feeding of material to the system. The required amount of input materials is calculated based on the expected production capacity in a given week. TOC, on the other hand, incorporates the limited capacity of critical production units in the planning calculations (Spencer, 1991:24).

Embedding TOC in MRP through a number of steps can be summarized as follows:

Identify the constraint, define buffers, improve operation routes and lead times, determine drum program and calculate MPS, use MRP calculus, and finally perform production control and performance evaluation.

Spencer (1991) makes appropriate comments for using the concepts of the book "The Goal" in an MRP system. He believes that bottlenecks should be identified first based on the machines loading reports in MRP. Then, a constraint program should be developed for bottlenecks. Following the bottleneck's programming, that is the Drum, MPS planning is made to feed MRP. In MPS, the products whose components will face the bottlenecks will appear. In the next step, he recommends creation of time buffers for MRP times that are less than a week. The last step is creation of Robes which provide sufficient input material to the system to support the operation of the bottleneck. This goal is accomplished by backward programming from the bottleneck towards the first operation of bottleneck support action.

Rimmer (1991) reported a case study on the integration of TOC and MRP in Valmont Company in Texas. The company produces steel towers and has 7 - 8 active units and 40 work centers. The constraints were the welding center and assembly line. The drum program was created daily in the constraint centers by planning the progress of others. Following this, the starting time of other work centers was programmed through the backward planning of MRP. A constraint buffer of a size of 6 days was also considered which was later reduced to 5 days via buffer management. The excess times in non-constraints centers were used for cleaning, painting, and preventive maintenance. The performance of the constraints was measured with traditional norms of performance and that of non-constraints was measured with gaps in the buffer. The performance results obtained between 1986 - 1990 were summarized in terms of income, stock turnover, delivery time, and average delays.

Bern and Jackson (1994) presented another case study of a production company utilizing MRP. They studied the

improvement effects of bottlenecks on the system through computer simulations and concluded that elevation of bottlenecks in the MRP environment increases WIP levels and output, as well as raising the credibility of MRP programs.

**RESEARCH METHOD**

This paper’s research method can be characterized as field-descriptive as it made use of the field information collected from Diecast Aluminum Bending and Casting Company of Tabriz.

In this research, the slip card method was used to collect and collate the theoretical background and literature. The research question was addressed by analyzing documents and information collected.

**Method of information analysis**

The information collected about the research variables was compared before and after the implementation of TOC. The results are analyzed by descriptive–analytic statistics and the effects of implementing TOC in a production environment are discussed.

As previously stated, one of the applications of TOC is in production planning. A thorough review of the many books and papers written on this subject shows that most of the authors introduced TOC philosophy without adequately discussing its application. We have tried to introduce an innovative and systematic method in order to use the five steps of TOC in a production site.

**Proposed methodology**

Initial steps to use the proposed methodology were discussed. Before utilizing TOC in a production environment, it is necessary to take the following steps:

- Make a list of existing machinery and resources in the production site
- Specify production items and the end product
- List and specify the raw material
- Graph production process structure

**Problem formulation**

Assume the following notations.

- $N$  : Number of produced items
- $M$  : Number of work centers (resources)
- $L$  : ( $L \leq K$ ) Number of unavailable raw material
- $i$  : Index of products
- $j$  : Index of resources
- $k$  : Index of raw material
- $K$  : Raw material including unavailable materials
- $I$  : Index of unattainable raw material
- $I_{i,t-l}$  : initial inventory for product  $i$
- $I_i$  : Final inventory for product  $i$

$D_i = d_i + I_{i,t} - I_{j,t-l}$  : production demand for product  $i$

$S_i$  : Units of product  $i$  sold

$RM_i$  : Raw material cost of product  $i$

$CM_i = S_i - RM_i$  : profit margin of product  $i$

$R_j$  : Units of available resource of type  $j$

$Set_j$  : lead time of resource  $j$

$NRM_l$  : Amount of unattainable raw material of type  $l$

$dt_j$  : Defect percentage of resource  $j$

$NRM_{lj}$  : Amount of raw material of type  $l$  for product  $i$

$NP_{ij}$  : Index  $f$

$NP_i$  : Number of required operations for product  $i$  by resource  $j$

$T_j$  : Time available for resource  $j$

$t_{ij}$  : Sum of the processing time of product  $i$  in resource  $j$

$P_{fji}$  : Coefficient of defect percentage

$t_{fji}$  : Processing time of operation  $f$  in machine  $j$  for product  $i$

**Computation  $P_{fji}$**

We illustrated the  $P_{fji}$  calculation method with a simple example. It is assumed that we would like to produce  $D$  units of a product using four machines (A,B,C, and D) and raw materials ( $RM_1, RM_2$ ). The product production structure had the following form:

The defect percentage of machines A and C was assumed to be  $d_A$  and  $d_C$  and there was no defect in the other machines. Since there was only one product, we set  $i$  to 1 and used the name of the machines instead of J. F for different machines as shown in Table 1. The production process structure is given in Figure 1. As an example, we calculated  $P_{1A1}$  as follows (Table 2):

$$P_{1A1} = P_{2B1} * \frac{1}{1 - dt_{P1A1}}$$

**Step 1: Identify the constraint(s)**

Determining bottlenecks by assuming known failure percentages for machines

- Identify resource bottlenecks

Determine parameter  $\alpha$  (number of loading in each operation) which is constant for all operations and depends on the size of product demands. Namely, it depends on the number of product

**Table 1.** Resource

| Resource | A | B | C | D |
|----------|---|---|---|---|
| F        | 2 | 2 | 1 | 1 |

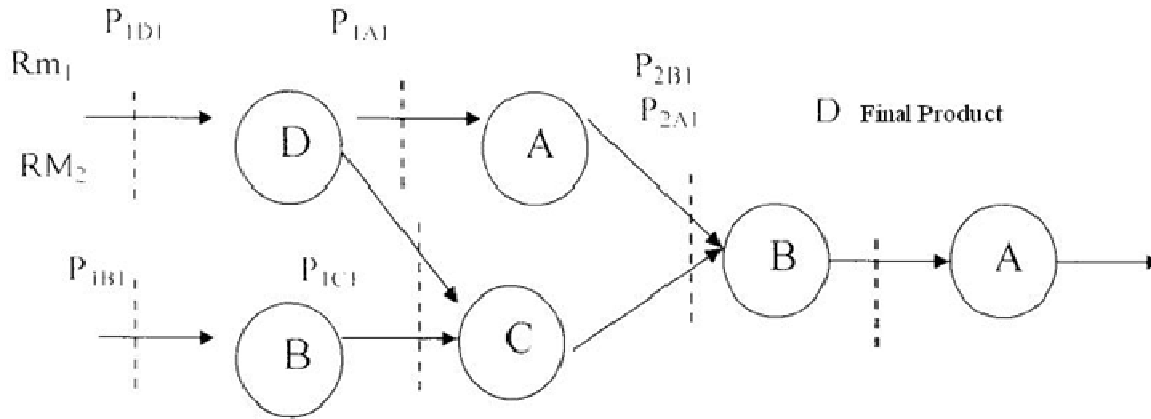

**Figure 1.** Production process structure.

**Table 2.** Computation  $P_{fij}$

|           |   |
|-----------|---|
| $P_{2A1}$ | $\frac{1}{1-d_A}$   |
| $P_{2B1}$ | $P_{2A1} \times \frac{1}{1-d_B} = \frac{1}{1-d_A} \times \frac{1}{1-d_B}$                                       |
| $P_{1A1}$ | $P_{2B1} \times \frac{1}{1-d_A} = \left(\frac{1}{1-d_A}\right)^2 \times \frac{1}{1-d_B}$                        |
| $P_{1C1}$ | $P_{2B1} \times \frac{1}{1-d_C} = \frac{1}{1-d_A} \times \frac{1}{1-d_B} \times \frac{1}{1-d_C}$                |
| $P_{2D1}$ | $(P_{2A1} + P_{1C1}) \times \frac{1}{1-d_B}$  |
| $P_{1B1}$ | $P_{1C1} \times \frac{1}{1-d_B} = \frac{1}{1-d_A} \times \left(\frac{1}{1-d_B}\right)^2 \times \frac{1}{1-d_C}$ |

planning performed in one period ( $\alpha \geq 1$ ).

- Determine the minimum setup time for resource  $j$  through the following formula:

$$\text{Minset} = \frac{\sum_i^N -_1 NP_{tj}}{R_j} \times \alpha \quad (j = 1, 2, \dots, M)$$

- Calculate the difference between capacity and amount of resource loading ( $dR_i$ )

$$dR_{j=Tj} = \left[ \frac{\sum_i^N = tDt \times dtj}{R_j} + \text{Minset} \times \text{Setj} \right]$$

( $j = 1, 2, \dots, M$ )

Then, a set of resource bottlenecks can be obtained.

$$CR_l = \{BN_1, BN_2, \dots, BN_q\} \quad q \leq M, \quad dR_q \leq 0$$

$$dR_1 \leq dR_2 \leq \dots \leq dR_q$$

- Identify bottlenecks in unattainable raw material

The difference between the required and consumed materials is calculated by:

$$dMR1 = NRM1 - \sum_{i=t}^N Dt \times NRM1, l = 1.2...L$$

The bottleneck set of raw material ( $CR_l$ ) is determined by:

$$CR_2 = \{BNRM_1, BNRM_2, \dots, BNRM_p\} \quad P \leq L, \quad dRM_p \leq 0$$

$$dRM_1 \leq dRM_2 \leq \dots \leq dRM_p$$

- Identify market demand bottlenecks

If there are no constraints in resource and unattainable raw material of a product, the market demand for that product is considered as the demand constraint. In that case, the production planning should be based on the product market demand in the production process.

**Step 2 : Optimize the exploit of system constraints**

- determine optimum production using integer linear programming:

Objective function:  $Max \ Z = \sum_{i=1}^X X_i \times CM_i$

Resource constraints:  $\sum_{i=1}^M \sum_{j=1}^N \frac{X_i \times t_{ij}}{R_j} + Minset_j \times Set_j \leq T_j$

Unattainable raw material constraints:

$$\sum_{i=1}^M \sum_{j=1}^N X_i \times NRM_{li} \leq NRM_l$$

$$X_i \geq D_i \quad (i = 1, 2, \dots, N)$$

$$X_i \geq 0 \ \& \ integer$$

In which,  $X_i$  is the production amount of product  $i$ . If we assume a potential failure in at least one machine, we substitute  $t_{ij}$  with  $t'_{ij}$ , and  $X_i$  with  $X_i \times P_{rml}$ .

- Determine the other critical bottlenecks
- Timing of critical bottlenecks (determining the MPS table)
- Determine  $\alpha_i$  (the number of  $X_i$  product production burden)
- Determine the timing order of products with respect to the critical bottleneck ( $BN_i$ ) in descending order of profit margin rate

$$(RCM_i = \frac{CM_i}{t_i \times BN_i})$$

-Determine product production composition based on parameter  $\alpha_i$

- and the descending order of profit margin rate
- Time the critical bottlenecks based on the product production composition of previous step
- Select next critical bottleneck in line and plan for unprogrammed products based on the critical bottleneck  $BN_i$ .

**Step 3: Downgrade all other operations not proposed in step 2**

- Define time buffers
- Define time buffers before MPS table operations
- Define assembly buffer if necessary
- There is no theory or special rule for determining size of the buffers. Some believe the buffers should be fivefold greater than the preparation and operation times between raw material release and constraint. Others suggest that buffer sizes should be three times as much as the lead times.
- Plan release times of the raw material based on backward timing
- Based on the MPS table, calculate release times related to X using this formula:

Release time of raw materials of operation X = start time of operation X from MPS - buffer time related to the operation route of the raw materials until they reach operation X

**Step 4: Elevate system constraints**

Based on TOC, in order to elevate the entire system, all of its constraints should be elevated by repeating steps 1 through 5.

**Step 5:**

If the constraint has moved in step 4, return to step 1 to prevent inertia from becoming the fundamental constraint of the system. If a constraint or a set of constraints were elevated in the previous step, return to step 1 and repeat the process.

**RESULTS AND CONCLUSIONS**

Theory of constraints (TOC) has been regarded as a new management philosophy and has proven to be adoptable to different applications. Although it involves a five-step process for production planning, there is still a gap between the theory and application. In this research, we made an attempt to augment the application value of TOC by introducing smaller steps and demonstrating them for a production line. This provided a systematic way to utilize TOC in production environments.

The results of the proposed methodology to the case study, Aluminum Bending and Casting Company, are as follows:

- We may neglect other constraints without considering the  $P_{fij}$  coefficient assumption. Even with elevation of current constraints, we may conclude that the same anticipated amount of production could not be produced. In this research, however, we were able to produce the anticipated amount of production by considering the  $P_{fij}$  coefficient.
- Even though the  $P_{fij}$  coefficient results are neglected in larger amount of anticipated production, it will not work

in practice and will give rise to increased number of work-in-process (WIP) items. This will in turn increase the maintenance cost and decrease profits. By considering the  $P_{ij}$  coefficient, we were able to prevent the accumulation of half-finished items in workstations.

- Many factors are typically involved in identification of system constraints. During this process, we realized that the process time alone is not a sufficient factor to identify system constraints. Ignoring other factors such as preparation times and failure rates of resources as well as the demand might lead to ignorance of the other constraints. In this research, we used the minimum amount of preparation time and coefficient, which led us to accurately recognize system constraints.

- If the critical constraints of the system are not correctly identified in steps 1 and 2, the non-critical constraints will mistakenly be elevated. This will result in excess costs and reduction of total profits. We avoided this problem by correctly identifying the critical constraints.

- The results show that the profits went up from \$16,839,140 before the elevation of system constraints to \$25,224,585 after the elevation as a result of the lengthened work-hours to match the difference between loading and available times.

## ACKNOWLEDGEMENTS

We thank Miss. Nayere Karegar and Mr. Hosein Badiie Shabgahi for their thorough review of this paper.

## REFERENCES

- Bern MD, Jackson RJ (1994). A study of bottlenecks in a MRP environment using simulation». *Int. J. Prod. Econ.*, 35: 115-120.
- Fox RE (1983). OPT vs. MRP: thought ware vs. Software». 26th Annual International Conference Proceedings, November.
- Goldratt EM (1990). *Theory of constraints*. New York: North River Press.
- Goldratt EM (1994). *It's not luck*. New York: North River Press.
- Goldratt EM, Fox RE (1986). *The Race*. New York- North River Press.
- Rahman S (1998). Theory of constants: a review of the philosophy and its applications. *Int. J. Operation Prod. Manage.* 18(4): 336-355.
- Rimmer G (1991). Material requirements planning and theory of constraints: can they coexist? a case Study». *Prod. Invent. Manage. J.*, Q4: 48-52.
- Spencer MS (1991). Using "The Goal" in an MRP system». *Production and Inventory Manage. J.* Q4, 22-27.
- Spencer MS, Cox JF (1995). Master production scheduling development.
- Swann D (1986). Using MRP for optimized schedules (emulating OPT)». *Prod. Invent. Manage.*, Q2: 30-37.